

Preventing Neural Tube Birth Defects:

A Prevention Model and Resource Guide



Preventing Neural Tube Birth Defects:

A Prevention Model and Resource Guide

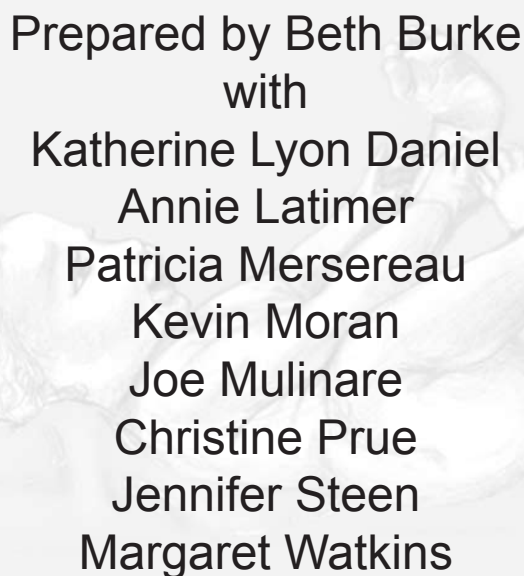

Prepared by Beth Burke
with
Katherine Lyon Daniel
Annie Latimer
Patricia Mersereau
Kevin Moran
Joe Mulinare
Christine Prue
Jennifer Steen
Margaret Watkins

Illustrations by Joey Johnson
with Vonetta Flowers



The Centers for Disease Control and Prevention (CDC) appreciates the work of the following individuals and organizations that contributed to the development of this document:

Individuals listed alphabetically: Teri Albrecht, Mike Andrews, Sandra Benton-Davis, Alison Berry, Barbara Bowman, Kristin Broome, Jim Buehler, Dee Bullard, Magdalena Castro-Lewis, Cathy Church-Balin, Carole Craft, Karen Dalenius, Charlotte Dickinson, Vickie Elisa, Deborah Hall, Laurie Hall, Mary Ann Henson, Amy Hepburn, Michael Kramer, Jeanne Latham, Shira Ledman, Gregg Leeman, David Montanez, Amanda Nestor, Becky Nordmeyer, Lydia Ogden, Kay Pearson, C. Kay Smith-Akin, Doug Staples, Diana Swindel, Margaret Tate, Karen Thornton, Meredith Tiptman, Alice Trainer, Jocelyn Wheaton, Treeby Williamson Brown, and Susan Winckler.

Organizations listed alphabetically: American Academy of Pediatrics, American College of Obstetricians and Gynecologists, American Pharmaceutical Association, Association of Maternal and Child Health Programs, Association of State and Territorial Public Health Nutrition Directors, March of Dimes Birth Defects Foundation, National Coalition of Hispanic Health and Human Services Organization, Shriner's Hospitals for Children, and Spina Bifida Association of America.

First printing – November 1998
Second printing – March 1999
Third printing – October 2000
Fourth printing – January 2002
Fifth printing – December 2004
Sixth printing – April 2009

For more information about birth defect prevention, contact the Centers for Disease Control and Prevention at 1-800-CDC-INFO.

**Use of Tradenames is for identification only and does not constitute endorsement by the PHS or the US Department of Health and Human Services.*

Table of Contents

Preface	1
How This Guide Can Help You Help Others	3
How Folic Acid Can Prevent Some Birth Defects	4
About NTDs	5
What Is it Like to Live With an NTD?.....	7
Who Is at Risk For Having a Baby With an NTD?	8
About Folic Acid	9
When Do Women Need to Take Folic Acid?.....	10
How Much Folic Acid Is Needed to Prevent NTDs?	10
Are Women Getting Enough Folic Acid?	11
How Can Women Get Enough Folic Acid?	11
Can Women Get Too Much Folic Acid?.....	14
What Do These Options Mean For Women?.....	15
Step 1: Mobilize Your Community	17
1.1 Know Why You’re Acting	17
1.2 Involve Others	19
1.2-1 Identify Groups, Coalitions, Organizations, and Agencies.....	19
1.2-2 Assess Potential Partners	21
1.2-3 Invite Other Partners	23
1.2-4 Approach Potential Partners.....	26
1.3 Define the Roles of Participating Groups	29
1.3-1 Identify How the Group Makes Decisions and Communicates	29
1.3-2 Discuss and Determine Key Components of the Program	1
1.3-3 Be Aware of Possible Conflicts	31
1.3-4 Identify Effective Spokespersons	32

Step 2: Plan For Action	33
2.1 Learn About Your Audience	34
2.1-1 Identify What You Know and Need to Know	35
2.1-2 Identify the Different Groups of Reproductive-age Women in Your Community	36
2.1-3 Define Your Target Audience	39
2.1-4 Learn as Much as Possible About Your Target Audience	40
2.2 Plan the Program	45
2.2-1 Set Objectives and Determine Approaches	47
2.2-2 Plan Activities and Tasks	48
2.2-3 Determine How To Reach Your Audience.....	56
2.3 Identify the Timetable and Program Costs	60
2.3-1 Use a Timetable.....	60
2.3-2 Estimate Costs of Each Activity or Task	65
2.4 Locate Funding Sources	65
2.4-1 Identify Your Available Resources	65
2.4-2 Identify Where Your Resources Fall Short.....	66
2.4-3 Determine What You and Your Partners Can Do Together.....	66
2.4-4 Apply for Grants.....	70
2.4-5 Identify Sources of Money and In-Kind Services.....	71
2.4-6 Consider Final Items.....	72
Step 3: Test Your Messages and Materials	73
3.1 Create Message(s) for Your Intended Audience	74
3.2 Test Your Ideas With the Intended Audience	75
3.3 Use Pretest Results to Improve Your Materials	81
3.3-1 Look for Recurring Themes in What People Said	81
3.3-2 List Recurring Themes and Relate Them to the Materials	81
3.3-3 Adapt Your Materials, Incorporating the Major Themes	82

3.3-4	Pretest Your New Drafts	82
3.4	Show Your Revised Messages to Important Gatekeepers	84
Step 4: Deliver, Track, and Evaluate Your Program		85
4.1	Kick Off Your Program.....	85
4.1-1	Make Checklist for Activities	86
4.1-2	Prepare Packets	88
4.1-3	Train Partners and Volunteers	91
4.2	Keep Track of Your Program.....	92
4.3	Evaluate Your Program Effects.....	97
4.3-1	Review Your Program’s Goals, Objectives, and Resources	98
4.3-2	Decide How to Measure Your Results	101
4.3-3	Analyze the Data	112
4.3-4	Garner Support for the Program.....	114
4.3-5	Communicate Your Findings.....	114
Real World Examples		117
	One Message Sent Out Many Different Ways	117
	Focus Your Program Around a Celebrated Event.....	121
	A Low-Budget Campaign Well-Planned From Beginning to End	123
	See Results From a Long-Term Commitment to NTD Prevention	125
	Collaborate in New Ways.....	127
	Start Young: A School Intervention.....	129
	Possibilities for Direct Folic Acid Supplementation and Evaluation	132
	Selected Ideas for Community-Based Folic Acid Promotion Programs	134
	Ideas for Health Care Providers.....	137
	Keep Up with New Campaign Ideas	138

Glossary of Terms	140
Contents of Appendices	143
Evaluation Form	147

PREFACE

Birth defects of any type have a major impact on the lives of affected children and their families. This guide outlines various ways you can design, develop, deliver, and evaluate a neural tube defects prevention program in your community using folic acid promotion as a model. Many of these materials have been designed to be general in nature so that they may be used for other types of birth defects prevention efforts in the future.

The U.S. Public Health Service recommends that to reduce the risk of having a pregnancy affected by spina bifida or anencephaly, women capable of becoming pregnant need to consume 400 micrograms (0.4 milligram) of synthetic folic acid daily from a vitamin supplement, breakfast cereals or other fortified foods, in addition to eating a healthy diet. Most women still do not know about the benefits of folic acid, nor do they consume adequate amounts of folic acid daily to prevent spina bifida and other neural tube defects. This guide is a step-by-step approach intended to help you develop a successful birth defects prevention campaign.

Improving infant health is a high national priority. An objective in the Healthy People 2010 plan is to reduce the number of babies affected by spina bifida and anencephaly by half. We look forward to working with you to make this prevention opportunity a reality.

Division of Birth Defects and Developmental Disabilities
National Center on Birth Defects and Developmental Disabilities
Centers for Disease Control and Prevention

How This Guide Can Help You Help Others

You can take many different approaches to increasing the number of childbearing-age women in your community who consume enough folic acid each day to minimize their risk of having a child with an NTD (neural tube defect). *Preventing Neural Tube Birth Defects: A Prevention Model and Resource Guide* demonstrates how you can design, develop, deliver, and evaluate a birth defects prevention program. The accompanying appendices, provided on diskette, include sample materials such as cover letters, news releases, public service announcements, tested survey questions, and other tools for you to use or adapt in conducting your program. The glossary, Appendix A, is also printed at the end of this text for your reference. Throughout the guide are examples of real-life folic acid campaigns to spark your creativity in developing each step of your community's program. Both the sample materials on the diskette and the real-life examples should help you to design and carry out your program.

This guide's step-by-step process can also help you to design, develop, deliver, and evaluate other public health awareness campaigns and birth defects prevention programs in your community. If you have any questions about this guide, please call 1-800-CDC-INFO (232-4636) or send an e-mail to flo@cdc.gov.

How Folic Acid Can Prevent Some Birth Defects

By educating women about the importance of folic acid and encouraging them to increase their intake, your community can have a direct effect on the lives of families and the health of their babies. Birth defects of the spine and brain can cause severe disabilities or death. Previously, approximately 4,000 pregnancies in the United States were affected by a defect of the spine (spina bifida) or brain (anencephaly), also known as NTDs (neural tube defects). Since 1998 when fortification of cereal grain products was mandated, that number has declined to approximately 3,000 pregnancies affected each year. The B-vitamin folic acid can help to prevent 50 to 70 percent of these birth defects every year.¹ However, most women do not consume enough folic acid daily to protect against these serious birth defects. Public health education about folic acid is just beginning.

To get the recommended amount of folic acid each day, most women will need to change their behaviors either to take vitamin supplements that contain folic acid or to consume sufficient amounts of breakfast cereals and other foods fortified with folic acid. This guide provides ways for you to increase the knowledge of reproductive-age women regarding the need to consume adequate amounts of folic acid. With that knowledge, they can maximize their chances of having a healthy pregnancy and minimize their chances of having a baby born with one of these serious birth defects.

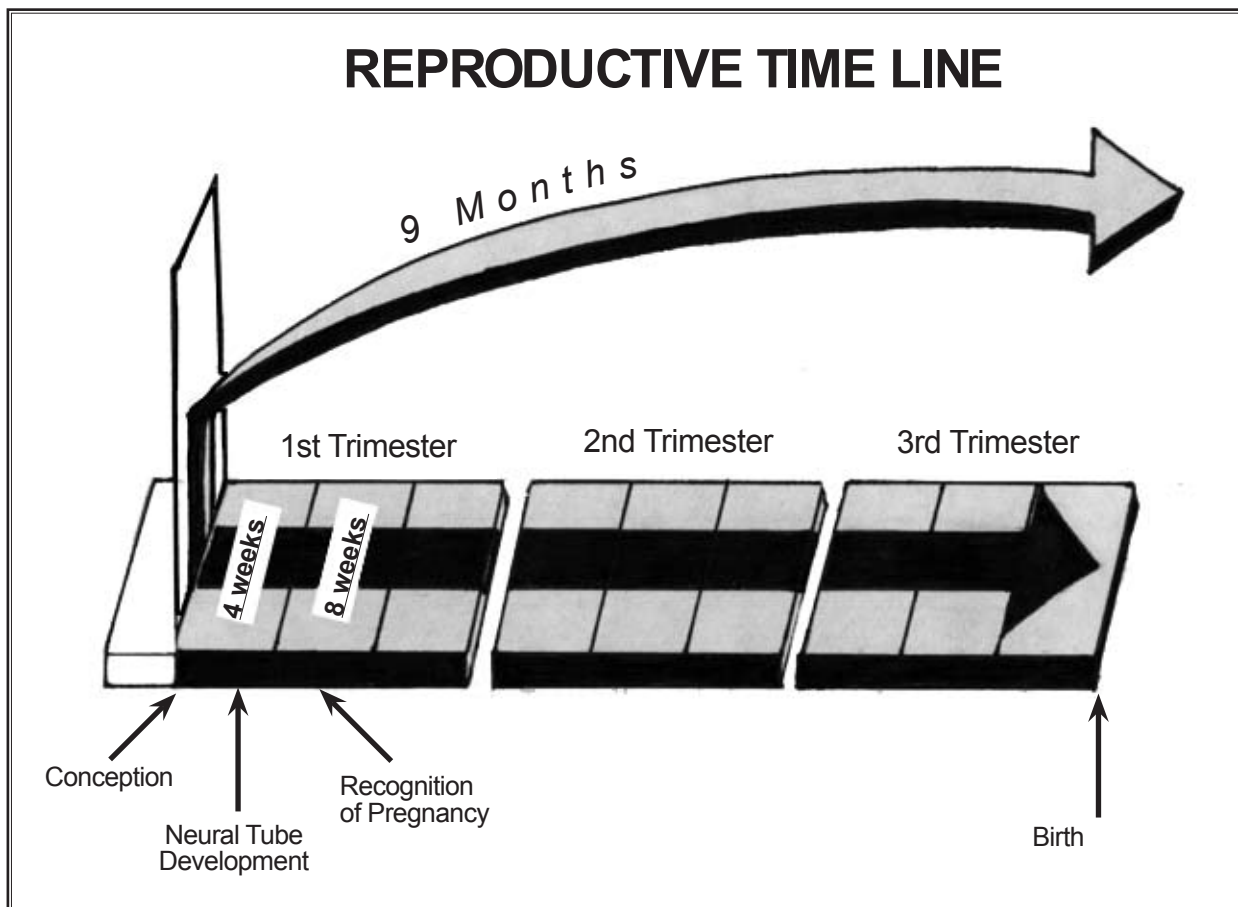

About NTDs

NTDs (neural tube defects) are birth defects that occur very early in pregnancy. The defects develop between the 17th and 30th day after conception (four to six weeks after the first day of a woman's last menstrual period), usually before a woman knows she is pregnant. During this critical time of pregnancy, the proper formation and closure of the neural tube, which later becomes the spinal cord, brain, and bone surrounding the spinal cord and brain, normally takes place. An NTD occurs when the neural tube fails to close properly.

Anencephaly and **spina bifida** are the two most common NTDs. *Anencephaly* is a fatal condition in which the upper end of the neural tube fails to close.

In these cases, the brain fails to develop completely or is entirely absent. Pregnancies affected by anencephaly often result in miscarriages, and the infants who are born alive die very soon after birth.

Spina bifida occurs when the lower end of the neural tube fails to close. As a result, the spinal cord and back bones do not develop properly. Sometimes a sac of fluid protrudes through an opening in the back, and often a portion of the spinal cord is contained in this sac. Paralysis of the infant's legs, loss of bowel and bladder control, hydrocephalus ("water on the brain"), and learning disabilities are often associated with spina bifida. Eighty to 90% of infants born with spina bifida survive. Despite varying degrees of disability, many lead long, successful, and productive lives.

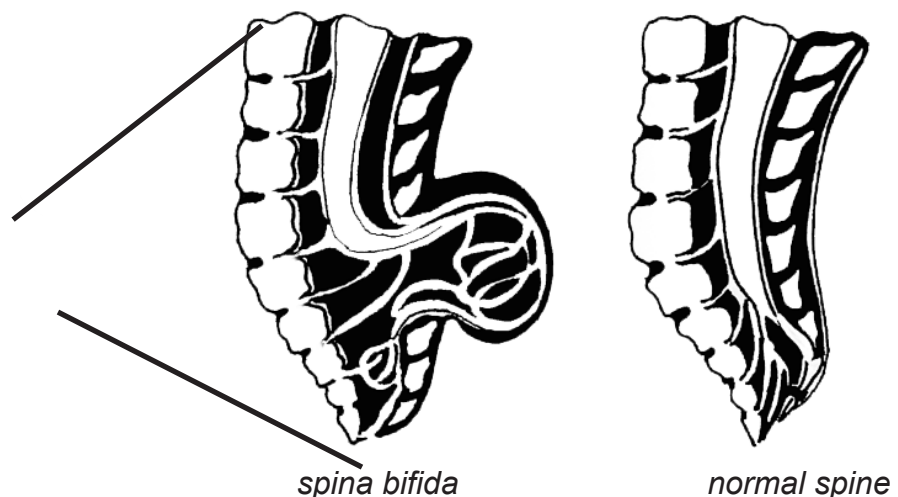

What Is it Like to Live With an NTD?

Both prevention and treatment of NTDs—spina bifida and anencephaly—are important. NTDs impact not only the life of a child and those of his or her family, but the community as well. As a child with spina bifida grows older, he or she faces unique economic, educational, medical, health, and emotional issues. Paralysis of the legs and bowel and bladder management problems are common for those with spina bifida. These problems may affect a person's health, self esteem, personal interactions, and work and recreational opportunities.

Despite physical and mental challenges, many people with spina bifida live independently. Today, mental retardation caused by hydrocephalus, a complication of spina bifida, is uncommon because of early medical and surgical treatment. However, learning disabilities are common. Although medical care has greatly improved the survival rates and quality of life of children with spina bifida, the children and families affected live with varying degrees of physical and social challenges for life. Additional references on neural tube defects and a list of supportive organizations for parents and children affected by spina bifida are included in Appendix B.

Who Is at Risk for Having a Baby With an NTD?

In June 2006, 61.7 million women were in the principle childbearing ages of 15-44 years. Any woman who is capable of becoming pregnant could have an NTD-affected pregnancy. It is not possible to predict which women will have a pregnancy affected by an NTD. Ninety-five percent of women with NTD-affected pregnancies have no personal or family history of NTDs. However, some risk factors are known. These include:

- A previous NTD-affected pregnancy. (This increases a woman's chance of having another NTD-affected pregnancy by approximately 20 times.)
- Maternal insulin-dependent diabetes.
- Use of anti-seizure medication. (Valproic Acid/Depakene[®] and Carbamazapine.)
- Medically diagnosed obesity. The body-mass index is used to determine obesity. (For more information on this measurement, see <http://www.nhlbisupport.com/bmi/>).
- Exposure to high temperatures in early pregnancy. (For example, prolonged high fevers and hot-tub use.)
- Race/ethnicity. (NTDs are more common among white women than black women and more common among Hispanic women than non-Hispanic women.)
- Lower socio-economic status.

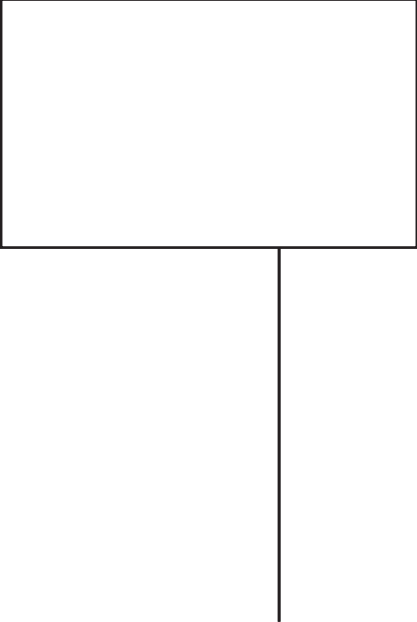

Appendix C contains a list of health care professionals and organizations that can provide advice and assistance on these issues.

About Folic Acid

Folic acid in a vitamin supplement, when taken one month before conception and throughout the first trimester, has been proven to reduce the risk for an NTD-affected pregnancy by 50% to 70%. Folic acid, a B-vitamin, is necessary for proper cell growth and development of the embryo. Although it is not known exactly how folic acid works to prevent NTDs, its role in tissue formation is essential. Folic acid is required for the production of DNA, which is necessary for the rapid cell growth needed to make fetal tissues and organs early in pregnancy. **That is why it is important for a woman to have enough folic acid in her body both before and during pregnancy.**

Folate and folic acid are different terms for the same B-vitamin. While these two terms are often used interchangeably, we make some distinctions between them. Folate is the B-vitamin form found naturally in foods. Folic acid is not found in natural food sources. Folic acid is the synthetic B-vitamin form that is used in vitamin supplements and added to fortified foods. **Synthetic folic acid is absorbed better than natural food folate.**²

Most of the folate found naturally in foods has a more complex structure than the synthetic folic acid which is found in fortified foods and vitamin supplements. The more complex structure affects the intestine's ability to process and absorb food folate. The body can absorb and use the folic acid found in vitamin supplements and fortified foods more efficiently than it can convert the food folate into a usable form. Synthetic folic acid is about twice as absorbable as naturally occurring food folate.³



When Do Women Need to Take Folic Acid?

Women need to get enough folic acid every day throughout their reproductive years. To prevent NTDs, a woman must take folic acid daily at *least* one month before she conceives and continue taking it through the first trimester (three months) of pregnancy. *All women capable of becoming pregnant—not just those planning a pregnancy—should consume enough folic acid every day*, because half of all the pregnancies in the United States are unplanned. Remember, NTDs occur before many women know that they are pregnant.

How Much Folic Acid Is Needed to Prevent NTDs?

- In 1992, the U. S. Public Health Service (PHS) recommended that all women of childbearing age consume 400 micrograms (0.4 milligram) of folic acid every day to reduce their risk of having an NTD-affected pregnancy.
- For women who have already had an NTD-affected pregnancy, the PHS recommends consulting with a doctor about taking a much larger amount of folic acid (4000 micrograms [4 milligrams]), starting one month before conception and continuing throughout the first three months of pregnancy.
- In 1998, the Institute of Medicine (IOM) recommended that to reduce their risk for an NTD-affected pregnancy, women capable of becoming pregnant should take 400 micrograms of synthetic folic acid daily, from fortified foods or supplements or a combination of the two, in addition to consuming food folate from a varied diet.

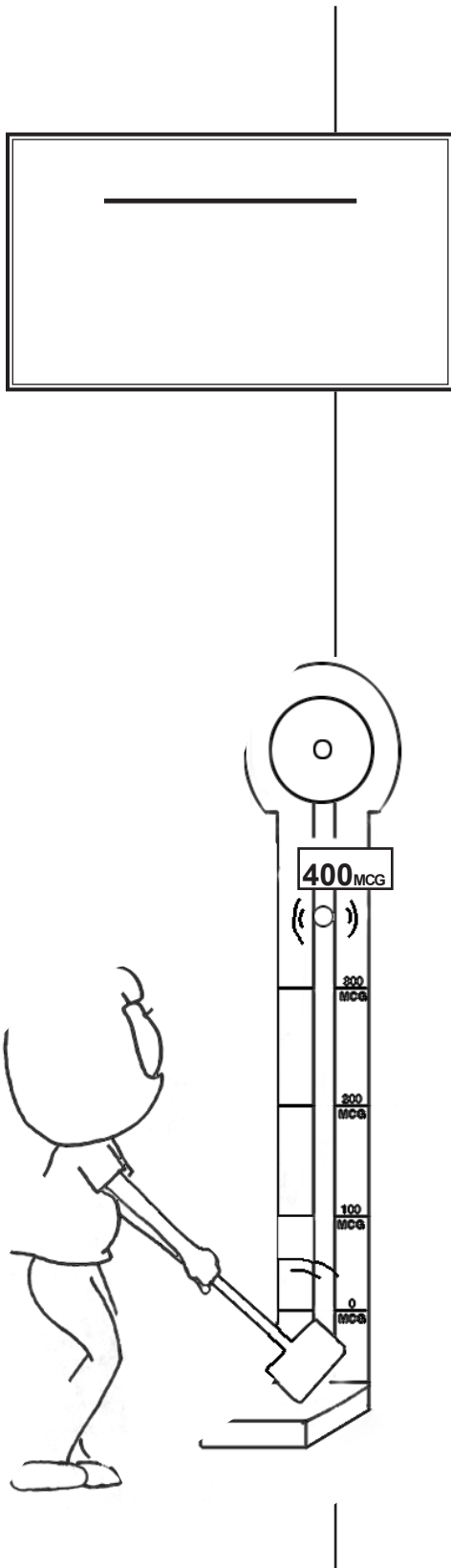

Are Women Getting Enough Folic Acid?

Two-thirds of women in the United States report consuming **insufficient** levels of folic acid, even though there are several ways to get 400 micrograms of folic acid a day.

How Can Women Get Enough Folic Acid?

There are three ways women can get enough folic acid to prevent spina bifida and anencephaly. They can choose to:

1. **Take a vitamin supplement containing 400 micrograms of folic acid daily.**
2. **Eat a fortified breakfast cereal daily which contains 100% of the recommended daily amount of folic acid (400 micrograms).**
3. **Increase consumption of foods fortified with folic acid (e.g., “enriched” cereal, bread, rice, pasta, and other grain products) in addition to consuming food folate from a varied diet (e.g., orange juice and green vegetables).**



1. Take a vitamin supplement with 400 micrograms of folic acid daily.

Taking a vitamin supplement containing folic acid is an easy way to get enough folic acid. Almost all over-the-counter multivitamins contain 400 micrograms (0.4 milligram) of folic acid, the amount recommended to prevent NTDs. The label on a multivitamin container will list a vitamin supplement's contents. Recently, more stores are carrying supplements containing folic acid alone. The cost of vitamins can vary considerably, but women can buy vitamins containing folic acid for as little as 50¢ to \$1.00 a month.

A woman should understand that taking too many vitamin supplements is not good for her or her baby. Caution should be taken to prevent the excessive use of multivitamin supplements. Very large amounts of some vitamins can cause problems. For example, too much vitamin A may cause other types of birth defects.

According to the 2008 March of Dimes survey, 39% of women, ages 18-45, take a daily multivitamin supplement containing folic acid. Among women age 25 and under, only 27% take a vitamin supplement daily.

Challenges faced by health educators and promoters include:

- Increasing knowledge of women, especially younger women, about the benefits of folic acid.
- Motivating women to get adequate amounts of folic acid daily.

- Informing women about reliable sources of synthetic folic acid.
- 2. Eat a fortified breakfast cereal daily which contains 100% of the recommended daily amount of folic acid (400 micrograms).**

A few cereals have enough added folic acid per serving to meet 100% of a woman's daily need. Fortified breakfast cereals that contain 100% of the recommended daily amount of folic acid (e.g., Total[®], Product 19[®], Multi-Grain Cheerios Plus[®], and Smart Start[®]) are good options for women who do not want to or cannot take a vitamin supplement.

- 3. Increase consumption of foods fortified with folic acid in addition to consuming food folate from a balanced diet.**

Effective January 1, 1998, the U. S. Food and Drug Administration ordered that all enriched cereal or grain products be fortified at a level of 140 micrograms (0.14 milligram) of folic acid per 100 grams of grain product. While this level of fortification offers some protection against NTDs, most women will not get enough folic acid through fortified grain products alone.

In addition to getting 400 micrograms of synthetic folic acid, women should consume food folate from a variety of foods. Foods rich in folate include orange juice from concentrate, dark-green leafy vegetables (e.g., spinach, broccoli, asparagus, and romaine lettuce), beans, grains, citrus and other fruits (e.g., kiwis and strawberries), and liver. A list of foods that are good sources of folic acid and folate is provided in Appendix B. However, women capable of becoming pregnant who eat a healthy diet still need to take a vitamin supplement, eat a breakfast cereal containing 100% of the daily value of folic acid daily or increase their consumption of foods fortified with folic acid to achieve the recommended amount of folic acid for the prevention of NTDs.⁵

Can Women Get Too Much Folic Acid?

If a woman of reproductive age were to eat a bowl of fortified cereal (100 to 400 micrograms), take a vitamin containing 400 micrograms (0.4 milligram) of folic acid, and eat foods rich in folate in one day, she would not have a problem with too much folic acid. Even in very high amounts, folic acid is nontoxic.⁶ Nevertheless, with the exception of women who have had a prior NTD-affected pregnancy, it is recommended that women consume no more than 1,000 micrograms of synthetic folic acid a day.⁷ (See box).

What Do These Options Mean for Women?

A diet rich in food folate is healthy and highly recommended. There are a few studies that suggest food folate may reduce the risk for NTDs. However, this is still in question.⁸ The PHS recommendation for NTD prevention is based on studies of synthetic folic acid from supplements that women took in addition to their regular diets. Fortifying the food supply is an excellent way to increase consumption of folic acid without requiring women to change their behaviors. However, fortification at the 1998 level will not prevent all folic acid-preventable NTD-affected pregnancies unless women are educated to change the way they eat.

To prevent NTDs, women will need to take a folic acid-containing vitamin daily, eat a fortified breakfast cereal containing 100% of the daily value of folic acid, or increase their consumption of foods fortified with folic acid in addition to consuming food folate from a balanced diet.

Incorporating these behavior changes into women's lives will prevent a significant proportion of NTDs and also contribute to women's good health. To help answer frequently asked questions about folic acid that are not detailed in this introduction look in Appendix B. The next step is a guide for planning a successful NTD prevention campaign.

End Notes

1. CDC. Recommendations for the use of folic acid to reduce the number of cases of spina bifida and other neural tube defects. MMWR 1992; 41(no. RR-14): 2-3.
2. IOM (Institute of Medicine). Dietary reference intakes: folate, other B-vitamins, and Choline: prepublication copy. In: Dietary Reference Intakes for Thiamin, Riboflavin, Vitamin B6, Folate, Vitamin B12, Pantothenic acid, Biotin, and Choline. Washington, DC: National Academy Press, 1998. Chapter 8, page 11.
3. Op cit, IOM. Chapter 8, page 1.
4. Cuskelly GJ, McNulty H, Scott JM. Effect of increasing dietary folate on red-cell folate: implications for the prevention of neural tube defects. Lancet 1996; 347: 657-9.
5. Op cit, IOM. Chapter 8, page 32.
6. Shils M, Young V. Modern Nutrition in Health and Disease. Philadelphia: Lea & Febiger, 1988.
7. Op cit, IOM. Chapter 8, page 45.
8. Op cit, IOM. Chapter 8, page 32.
9. Watkins ML, Scanlon KS, Mulinare J, Khoury MJ, (1996): Is maternal obesity a risk factor for anencephaly and spina bifida? Epidemiology 7:507- 512.

Step 1: Mobilize Your Community

Step 1 will help you to:

- Communicate with others why efforts to promote the use of folic acid among women of childbearing age are important in your community.
- Decide who will be able to help you plan your program and how to ask them to participate.
- Determine how the group(s) will work together to make an effective prevention team.

1.1. Know Why You Are Acting

State the reason why you want to do something about birth defects in your community. Answering some or any of the questions below might give you a reason to act.

- How many infants are born with NTDs in my community every year?
- How many women of childbearing age in my community know about folic acid?

- Are women of childbearing age in my community getting enough folic acid?
- Is a large population in my community at higher risk for having babies with NTDs?
- Are there people in this community who are committed to helping others have healthy babies?

If you do not know what the issue is in your community, **Section 1. 2 “Involve Others”** will help you gather a group of people together who can help define your community’s issue(s). Also, in Appendix C, you can find a list of each state’s health department birth defects surveillance contact. These individuals may be able to provide you with the number of NTDs that occur in your state every year. Remember that compelling data isn’t the only reason people may want to respond. People who have personally experienced having a baby with a birth defect, who have known someone who has had a baby with a birth defect, or who simply want babies to be healthy may wish to participate in activities to promote the use of folic acid among women of childbearing age.



As you plan your program and develop partnerships, be sure to think about how you will evaluate the success of your efforts. More information about evaluation planning is on pages 55-56 and in section 4.3, starting on page 97.

1.2. Involve Others

A diverse group of public, private, and civic agencies/organizations that can provide information about women in your community should be involved in your prevention program's planning, implementation, and evaluation activities. Successful prevention programs focus their efforts toward their target audience's knowledge, beliefs, and behaviors. Community partners can increase the quality of your prevention program—making it more efficient, effective, and accessible to women.

1.2-1 Identify Groups, Coalitions, Organizations, and Agencies that May Be Able to Contribute to Your Program

A detailed list of potential partners in your community is provided in Appendix C. Remember that women of childbearing age in your community—your target audience—are great sources of information. Ask those women who they think would be most helpful to your program's prevention efforts. Also, think about:

- Groups with whom you have existing relationships or have collaborated on past projects.
- Partners already involved in birth defect prevention or maternal and child health.
- Groups who have women as members, customers, employees, or clients.

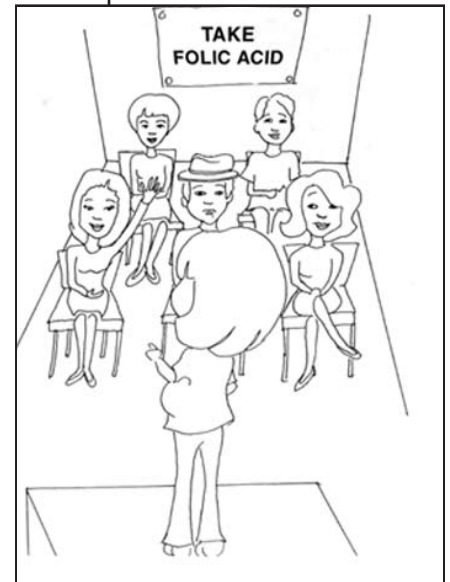

- Community-based organizations such as youth centers and religious institutions (churches, synagogues, temples, and so forth). These places are especially important when trying to reach special populations.
- Market-research firms, news agencies, or advertising agencies.



Partnering Tip

- *Partners, especially women of childbearing age, should be involved as early as possible in planning the program. Be willing to adapt the program as new partners come on board.*
- *Groups that serve the health or educational needs of women in special populations, such as women of Hispanic origin, can provide valuable insight in planning, implementing, and evaluating your program. For instance, you may want to test the effectiveness of your prevention program's activity, ideas, or message at an English-as-a-Second-Language (ESL) class. In addition, ESL teachers may want to help you create materials understood by their students.*
- *Groups that provide nutrition information, free or low-cost vitamin supplements, fortified food products, and family planning services have been key resources in past campaigns.*
- *Market-research firms, newspaper agencies, or advertising agencies may be able to provide data on women in your community.*

1.2-2 Assess Potential Partners

The number of people who may be able to help in your community can seem overwhelming. Remember, more is not necessarily better. Think strategically about each organization, individual, or agency's contact with women of childbearing age and about how each might contribute to your program.

- How will they add to your capabilities?
- Do they have access to women in ways unavailable to you?
- Does their staff have skills you do not possess (for example, fluency in another language)?
- Do they have relationships or contacts with others who can expand your impact?

Aim to build a team of people who can share different perspectives about women of childbearing age in your community. Make a list of organizations that can reach many women and can have the most influence on women you want to reach. Prioritize this list, and make contacts in priority order. Following up with those organizations on your list is a good idea. You may also want to send an open invitation to agencies in your community and wait to hear responses.

Real World Examples

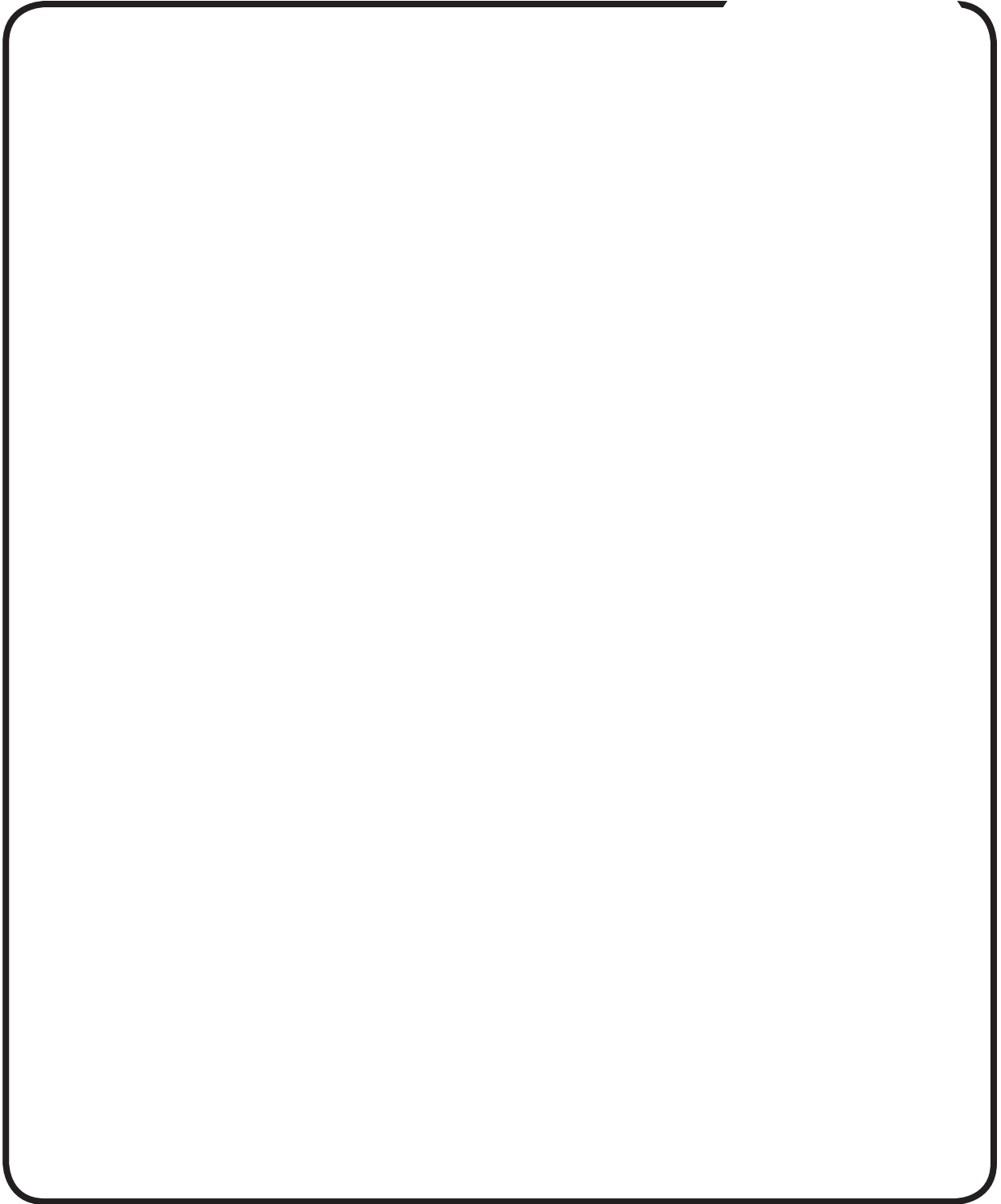

1.2-3 Invite Other Community Members

The process of introducing the prevention program to new individuals is time consuming. It involves telling people about the issue and convincing them to work with you to plan activities and recruit additional help. The benefits, however, are well worth the effort.

Real World Examples



The following is an ordered list of what you need to know to recruit partners for your prevention program:

1.2-3-a Plan ample time for partnering There are many ways to recruit partners and create collaborative relationships in your campaign, but this process takes time. Be sure to give yourself enough time to gather an effective group together to help promote folic acid in your community.

1.2-3-b Prepare to explain why others should become involved Following are some reasons applicable to a folic acid promotion program:

- Partners will be providing a useful public service.
- Volunteering improves a group's or a person's image and credibility in the community.
- The program may provide manufacturers of female products with useful information about certain female consumers' likes, dislikes, habits, and so forth.

Real World Examples

1.2-3-c Educate program staff and group members about partnering and its purpose

- *Some staff members may not understand why they cannot conduct the whole program themselves.* Explain that partnering with others might require modification of program goals, activity plans, time schedules, or even messages, but that these changes will most likely result in a greater impact on women in your community. This is everyone's goal.
- *Partnering requires respect for one another's opinions in making a decision, sharing responsibility and resources, and maintaining accountability.* Potential partners may not have the time or energy to be actively involved all the time in your program. They also may believe that the folic acid program takes away community resources they would have used for something else. Have your staff be aware of these possibilities so they are not disappointed if potential partners do not always put in a full-time effort toward your folic acid program. Remind the program staff that a little help is better than none. Also, a simple endorsement of your prevention campaign by an important stakeholder can open doors for you in the community.

1.2-4 Approach Potential Partners and Supporters Properly and Professionally

The way in which you approach various organizations and ask for help may differ, depending on the organization and how it does business. Some approaches include:

- **Contact people and organizations in person, if possible.** If time is an issue, plan a group meeting of representatives from potential organizations.
- **Solicit another group's involvement in a formal letter.** Letters written to a variety of potential partners can be found in Appendix D.
- **Ask for help on specific tasks.** Many people or organizations will assist if they know how they can make a realistic contribution. List a number of tasks that an organization could do for your program, along with a cover letter about your plan. Ask potential partners what they might need to implement such an activity or if they want to suggest any other activities that are not listed. Perhaps you have the resources to fill in their gaps. In addition, once a program gets underway, additional partners are often identified. Activity lists can also be used to identify activities that new partners may be interested in. In Appendix D, we have included other activity lists for specific groups that have helped in past folic acid promotion programs.

Following is a guide to writing your own cover letter and an example of a possible activity list for organizations. Adapt these examples or use those provided in the appendices to cater to the organizations and people in your community.



Soliciting Participation in a Folic Acid Promotion Effort

1. Introduce your project. (“We are setting up a folic acid promotion program to prevent birth defects.”)
2. Briefly tell about the health issue you are addressing (e.g., NTDs).
3. Provide a brief outline of your proposed goals and objectives.
4. Let potential participants know why you want them involved, and in what way. (For example, tell them that you would like their help in setting the program’s goals and objectives or in conducting audience research to ensure that your message is accurate and effective and that your time and money are well spent).
5. Propose a timetable for your program.
6. Tell potential partners that you would like their input on the program’s plans and progress during periodic review periods. Tell them that their opinion is important to you.

Note: Before you approach foundations, corporations, organizations, etc., research them! Their guidelines and restrictions may often influence how and what you ask for. You do not want to ask them for something they cannot provide. You may have only one chance to speak with these groups and convince them to help. More details about foundations and corporations can be found in Appendix E.

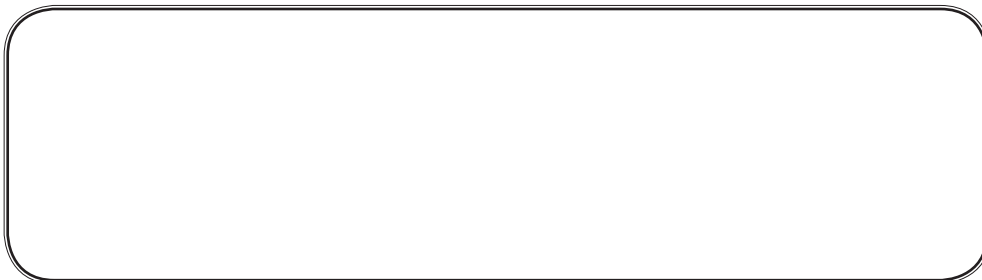

Possible Activity List for Organizations

Name:

Address:

Phone:

Check anywhere you can help in the following:

Planning Stage

- Join a folic acid program development committee.
- Assess community health issues and other resources.
- Collect data to help target women for the program.
- Identify health and other organizations and media outlets in the community.
- Identify available and appropriate folic acid communication materials.
- Help pretest materials.

Partnering

- Recruit volunteers, organizations, and media to participate in the program and/or to provide “in-kind” contributions to printing, collating, mailing services, public service space, or media costs.
- Provide marketing data about women.
- Help raise funds.
- Contribute staff or volunteer time.
- Produce messages and materials.

Implementation

- Provide room space for meetings and activities.
- Join a program development committee.
- Organize or participate in attention-getting events, such as health fairs and press conferences.
- Prepare press releases.
- Prepare exhibits for public places, such as shopping malls, building lobbies, schools, and public libraries.
- Distribute materials.
- Write letters.
- Publish articles in newsletters.
- Sponsor presentations.
- Offer individual counseling.
- Provide a recognized, credible spokesperson.
- Provide media interviews.

Evaluations

- Provide technical assistance with program evaluation or data analysis.
- Provide computer or manual services for tracking the program.
- Identify and train other organizations interested in becoming involved.
- Follow up by telephone with participants to ensure their continued involvement.
- Serve on “thank you” committees.

Other? Please tell us your suggestions.

1.3. Define the Roles of Participating Groups

Talk about the roles of the groups committed to the folic acid promotion program and the relationships among them. Establishing a committee whose structure allows efficient and productive communication and planning will mark the beginning of a successful collaborative effort.

1.3-1 Identify How the Group Makes Decisions and Communicates

A committee can play many different roles in a community's folic acid promotion program. The two examples follow: one committee served as an advisory board to a local health department, and the second committee worked together to plan their campaign. Regardless of the structure, the goal is to develop a committee that allows members with different perspectives to share their own opinions and expertise freely.

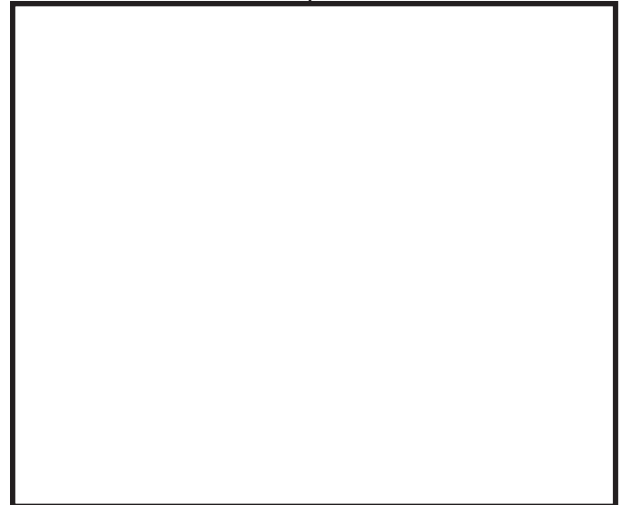

Real World Examples

--	--

1.3-2 Discuss and Determine Key Components of the Program

Topics to be discussed include:

- The program's goals and intended benefits.
- The roles and responsibilities of partners. For example, the need to report continuously on the partners' progress or plans to sustain folic acid prevention activities.
- The resources each partner can commit to the program.
- The contact person, address, phone and fax numbers, e-mail address and so forth for each organization.

This type of discussion will bring partners together for one common purpose, although they might be contributing resources and support in very different ways. Review the agreement reached as the result of your group's discussion and update it periodically.

1.3-3 Be Aware of Possible Conflicts So That You Can Be Prepared to Address Them

For example, some organizations may want to encourage women to get their folic acid strictly through natural and fortified foods and others strictly through supplements. Some may want to educate women about both options. Conflicts could arise over which options

your program will promote. Also think about groups or events that might increase the costs of your program or delay your timeline, and decide whether including those groups or events as part of your program is worth the possible delay or increased costs.

1.3-4 Identify Effective Spokespersons to Represent the Program

Spokespersons should be community leaders who are comfortable making presentations to various audiences, knowledgeable about folic acid and its role in preventing NTDs, and enthusiastic about your folic acid promotion program. Spokespersons also should be aware of special populations and their particular needs and approaches to health care.

Step 2: Plan for Action

Step 2 will help you to:

- Learn about and select a target audience.
- Set appropriate and effective program objectives and activities.
- Think about your program's timetable, costs and funding sources.

Every folic acid promotion/NTD prevention program's ultimate goals should be to prevent NTDs and to increase the proportion of women whose babies are healthy. Keep these overall goals in mind.

Your objectives and activities should take you toward these goals. To set appropriate objectives and plan effective activities for your prevention program, you will need to conduct audience research.

2.1 Learn About Your Audience

This section describes how to work with your partners to determine information that will allow you to select a *target audience* for your prevention program. At this point, though, do not spend too much time searching for information. Save your money and resources to do in-depth research on the group you actually select. Without too much work, you can obtain information through the following ways:

- Use your partners' experience and intuition.
- Call local market-research firms, advertising agencies or news agencies. If they do not have any information about the women in your community, they will know where to get it.
- Go to grocery stores and pharmacies to get information about sales of fortified foods, folate-rich foods, and multivitamins.
- Ask or survey women about their knowledge, attitudes, or behaviors regarding folic acid.

2.1-1 Identify What You Know and Need to Know

For instance, how many women in your community know that folic acid prevents NTDs? How many women in your community consume a multivitamin containing folic acid daily? How many births are affected by an NTD in your community?

Outline what you know and what you need to know about your community and its services, organizations, and groups that reach out to women of childbearing age. Seek answers to your questions by surveying or just simply speaking to women in WIC clinics, family planning clinics, physician offices, grocery stores, or other places where women visit in your community. Another option would be to conduct a focus group, which is explained in Appendix B. If you cannot use these resources at this stage, you can use national data and apply it to your community. Sources for national data can be found in Appendix B. Keep in mind the diversity in your area.

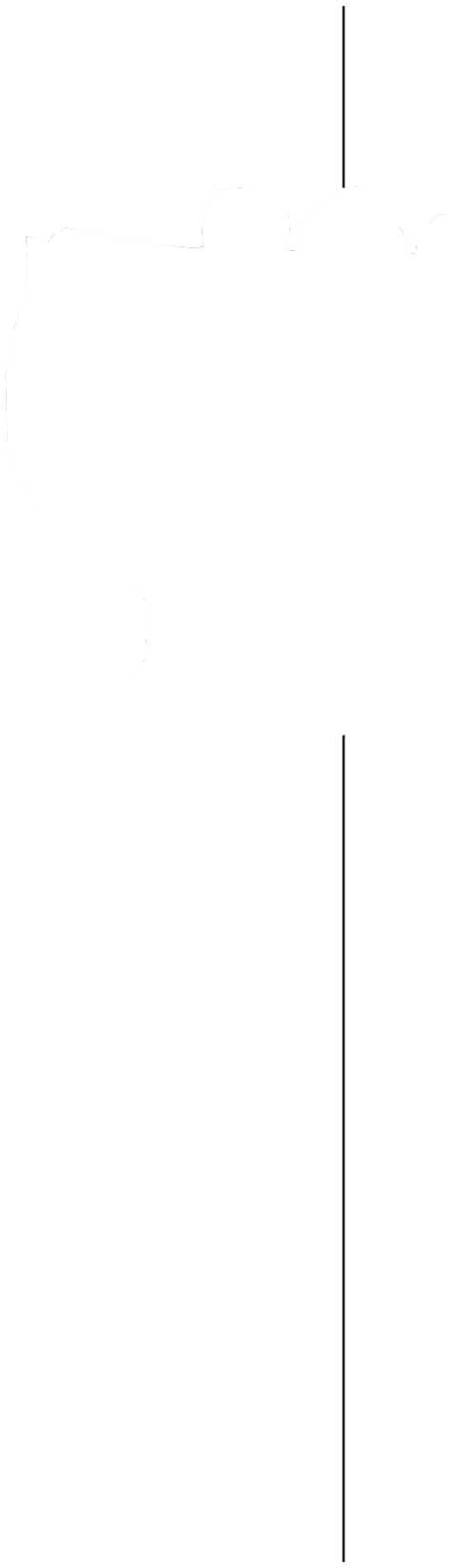

- **Geographic** variables—such as neighborhood, place of work, or place of recreation. For folic acid promotion, you might group women according to where they spend most of their time or where you might easily reach them. For instance, if you wanted to use direct mail to send free samples of folic acid supplements to women, grouping women by geographic variable would be best. Or, if many women of childbearing age in your community live in certain apartment complexes or attend meetings at a local organization, you can focus your intervention at those sites.
- **Lifestyle** variables—such as personal values, beliefs, preferences, and behavior patterns, including the way people live and spend their time and money. In the case of folic acid promotion, you might group women according to their pregnancy intentions. For example, some women intend never to get pregnant (regardless of what their contraceptive methods might be), some intend to get pregnant in the near future, some intend to get pregnant someday but not anytime soon, and so forth. Promoting folic acid to women grouped by these variables may mean producing different messages and materials for each group.
- **Behavioral** variables. In folic acid programs, you might group women according to whether they are using vitamins, eating foods fortified with folic acid, or using effective contraception. For example, although women in their 20s are more likely to become pregnant in the near future, fewer of them take vitamins than do women over age 30.



This information may lead you to narrow your target audience and to direct your messages to women in this younger age group.

There are many potential ways to group women of reproductive age. Consider the variables that you think will best influence the women you want to reach. In developing effective communication messages, you should not group women by demographic or geographic variables alone. *Communication messages that best influence women to increase their consumption of folic acid are devised on the basis of lifestyle and behavioral variables.* After using lifestyle and behavioral variables to choose your target audience(s), demographic and geographic information helps you to develop more effective objectives and activities for the target audience in your program.

For each variable, a woman should fall into only one category; that is, a woman cannot be in a group planning never to get pregnant and in a group planning to get pregnant someday at the same time. Careful grouping will increase your chances of changing women's behavior, because you can develop messages specifically for the interests of each of the different groups. Tailored messages for each group you select will help to make your communication program most effective.

2.1-3 Define Your Target Audience

Picking one group of women over another can be very hard; those of us who want to help others usually want to reach everyone. However, when we do not select one group to reach and proceed to design “generic” messages (as opposed to tailored messages), we cannot see much impact. Although they may reach everyone, generic messages do not influence most individual audience members in any meaningful way. You may reach everyone (100%) with a message, but if no one pays attention to it, understands it, or acts on it, the effort is wasted. Do not fall into the trap of thinking that one message will reach everyone: it will not!

The goal is to **“REACH AND RESONATE”**—

—that is, expose people to a message that gets their attention, comprehension, and action.

Following are some objective criteria for selecting one or two groups of women to reach:

- What is the size of the target audience? Can your organization impact a group of that size?
- What is the risk for NTDs in each group?
- What is the group's vulnerability to the issue? For example, are group members young, sexually active, and unable to obtain or consistently use birth control?
- Is the group ready to respond to a folic acid message? For example, if you want to target women of a low socio-economic level, identify those in your community who work with this group. Ask them how receptive they think this group would be to a message about folic acid.
- What is your capability of reaching the group?

2.1-4 Learn as Much as Possible About Your Target Audience

Knowing your audience well is the heart of designing health messages that will not only reach women but also resonate with them. Your program or activity can be most effective if you understand why the members of your audience act as they do. You should think carefully about why changing habitual behaviors will be attractive to the people you want to reach. The following section will help you to ask important questions about the group you have selected and then tell you how to gather answers to those questions. If you have enough resources, both time and money, consider reaching several groups of women.

Finding information about your target audience(s) will allow you to define appropriate objectives and plan effective activities, as well as to feel confident about your prevention efforts in the community.

2.1-4-a Find out about the beliefs, values, knowledge, and practices of the selected group(s) of women

- What are the women's knowledge levels about folic acid?
- What are women's attitudes toward their diets and taking vitamins? Do they think or feel that issues such as diet and folic acid may be important or relevant to improving the health of themselves, their children, or future children?
- What percentage of women in your target audience take vitamins?
- How do women in your target audience feel and think about health care professionals and medicine in general?
- How do women feel about their ability to change their lives? Do they feel in personal control of their lives or subject to the will of a higher power?

These characteristics may be defined on the basis of income, proximity to services, social norms, and the barriers and facilitators to obtaining enough folic acid daily. For example, some families in the Hispanic/Latina population may be undocumented immigrants. Because of their fear of deportation—a barrier to health care for these women—health clinics and doctors' offices may be off limits. In these cases, prevention programs may need to reach female undocumented immigrants in their homes (through, for

example, Spanish language radio stations). For other women, taking a vitamin supplement that contains iron may cause an upset stomach. Some women think remembering to take a multivitamin every day is too hard. But for many, taking a multivitamin is something they would do easily if their doctor recommended it to them. Market research data for 2008 revealed that approximately 89% of women in the United States reported they would take a multivitamin if it was recommended by their health care provider. However, only 41% of women ages 14-45 reported that their physicians currently recommend they take a multivitamin. Knowing what the barriers and facilitators are to supplement use will help you to set objectives and plan activities for specific groups of people (e.g., women, doctors and nurses).

You can understand how to influence behavior and identify approaches to doing so by answering as many questions as possible about your audience. Consider sources that can provide answers about your selected audience. The breakdown of your target audience by race/ethnicity, age, income and other factors is important background information, but such demographic data cannot fully describe your audience. At this stage, do not simply gather information that is taken from all women and use it to describe your selected audience. Collect information directly from the target audience in your community too.

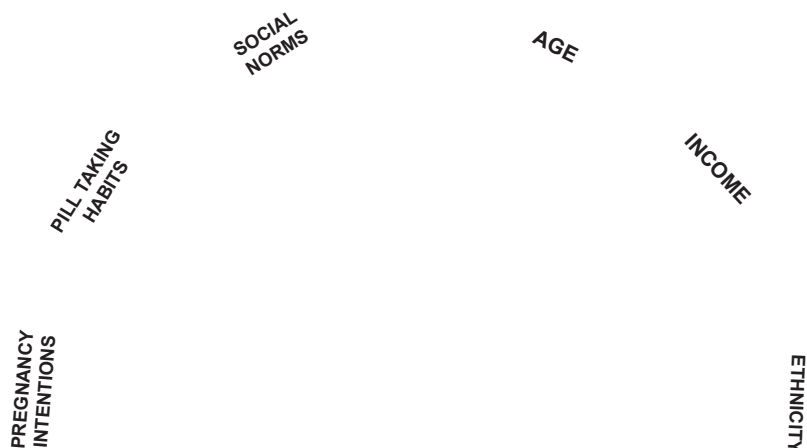

- Read what is written about the health beliefs and practices of women of reproductive age. See Appendix B for some references.
- Read what is written about other beliefs and practices of reproductive-age women that have nothing to do with health— such as those having to do with music, entertainment, work, and hobbies. Much of this information is provided in marketing literature. See Appendix B for references.
- Observe women in your community. To whom do they talk and listen? Where do they go and how do they get there? Where do they work and play? What do they do, read, watch, shop for, and eat?
- Conduct surveys of women through the mail, in person, or by phone. See “Step 4: Deliver, Track, and Evaluate Your Program” for detailed examples.
- Conduct discussions with groups of women.
- Try any of these suggestions until you have a better understanding of your audience to develop and deliver compelling messages for them. Appendix B provides more details to help you.



2.1-4-c Determine what the women in your target audience buy and do for fun

For instance, on the national level many women in the 25- to 35-year-old age group listen to the radio more often than they watch TV. Be aware, however, that activities in one region of the country may be very different from those in another. Call local radio stations, and ask how many listeners they have and what percentage of them are women in your target age range. Some other ideas to obtain information such as this include the following:

- Talk to representatives from a local marketing company. Ask these companies to share information with you *pro bono*. (You can offer to recognize their contributions on any written materials or at events you may hold.)
- Research what you can about women's buying behaviors, especially as related to vitamins or other health products. Surf the Internet for other relevant information.
- Find out about other prevention programs in the community. Whom do they serve, and what are their services?
- Determine the content of local media reports, and find out if you may be able to relate your folic acid promotion program to those news items. For example, can you relate your program to a large community event that gets good press coverage?
- Appendix B refers to some general characteristics about women's media habits. Note that some information is collected on the national level and does not necessarily reflect the uniqueness of your community.



2.2. Plan the Program

This section describes how to set objectives and plan audience-appropriate activities. Setting good objectives and planning audience-appropriate activities are crucial steps toward achieving your overall goal and to measuring your program's success. Following is a summary of a program plan which will be laid out step-by-step in this section.

2.2-1 Set Objectives and Determine Approaches

Clarifying your objectives is the first step in determining what kind of impact you would like to have in your community. Remember, you want to try to reach your target audience with messages that motivate them to achieve some specific objectives. As a result, you can reach the overall goal—to prevent birth defects and, thereby, increase the percentage of babies who are healthy. On the basis of what you and your committee know and have found out about your selected group(s) of women, set one or more objectives that are measurable and appropriate for your audience.

Step-by-step change is the most effective way to bring about behavior change. Women must be exposed to the folic acid message before they can be aware of it; they must be aware of the folic acid message before they can understand it; and, finally, they have to understand and personalize the folic acid message before they will change their behavior. The National Council on Folic Acid has drafted objectives and activities that are measurable and appropriate for its national audience.

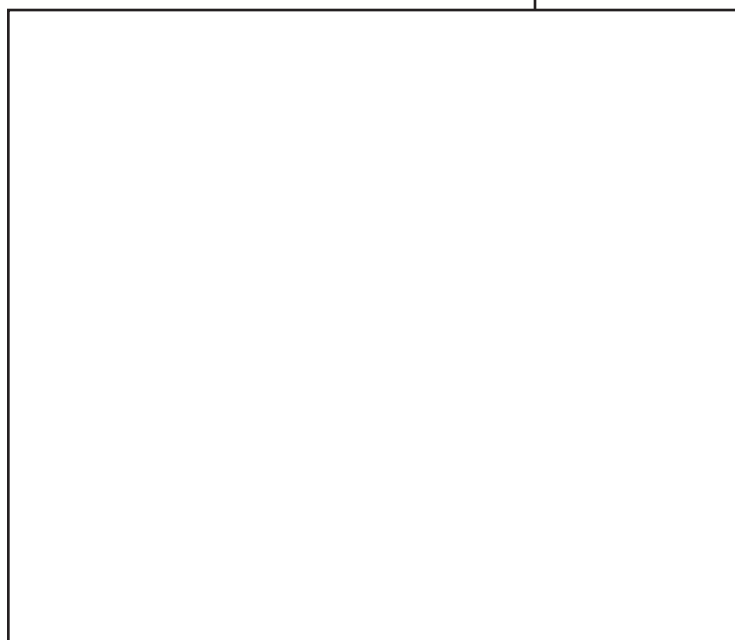

Real World Examples

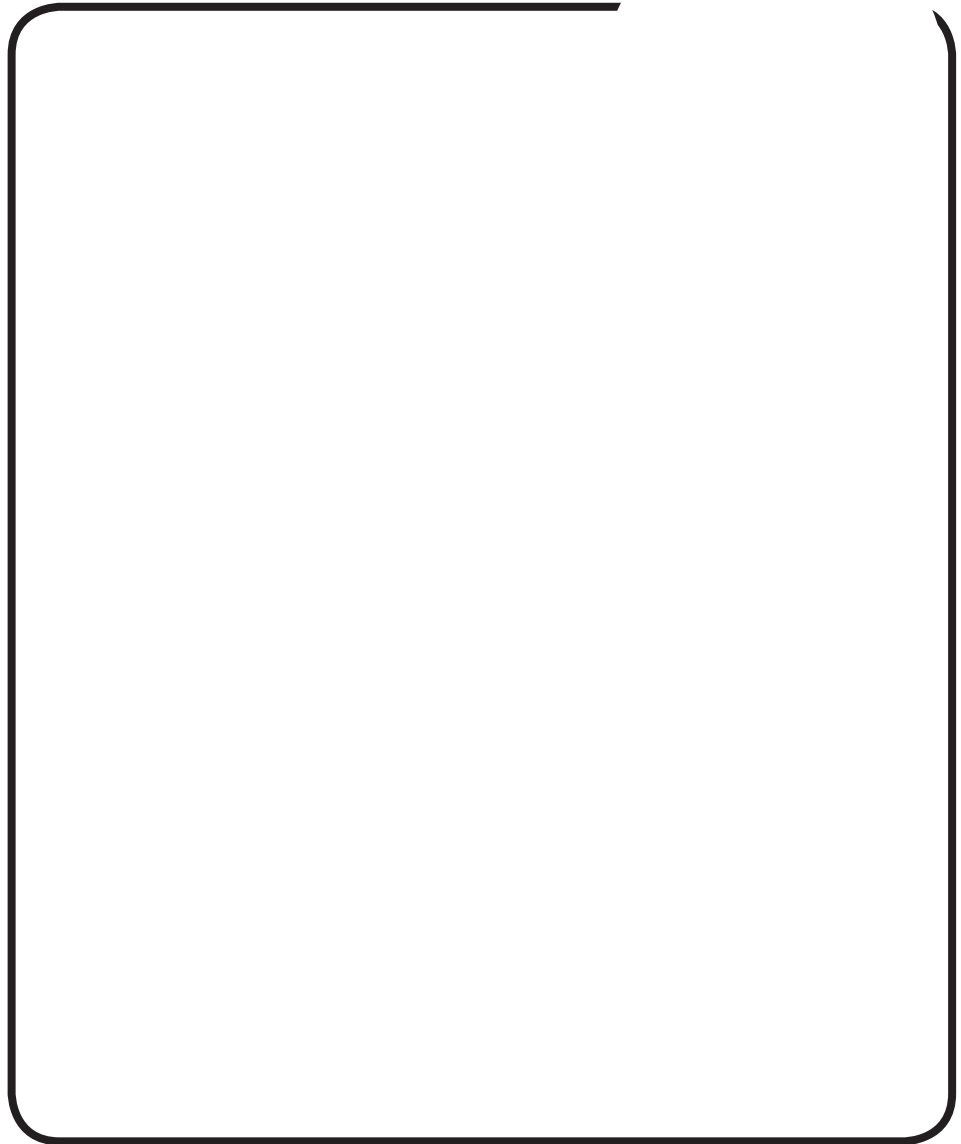

2.2.2 Plan Activities and Tasks

After determining the objective and selecting a broad approach, the Council planned activities that could be refined to include specific tasks for reaching health care professionals. One activity the Council chose to implement their approach was training health care providers and providing them with ready-to-use materials.

In planning activities or tasks, your committee can take broad approaches like the National Council did (which allows for variations in group members' tasks) or a more detailed approach that plans specific activities for the committee to implement as a whole. A program planning worksheet in Appendix E will help you brainstorm your objectives and activities. Some program activity ideas are provided in the "Real World Examples" chapter of this guide.

Real World Examples

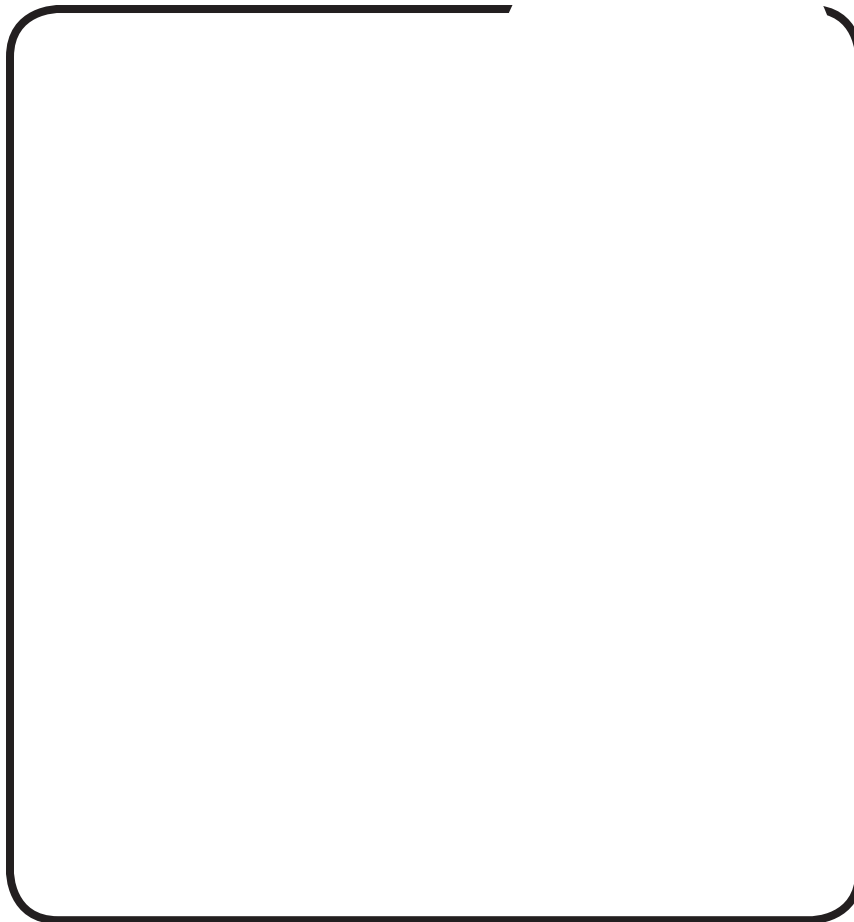

2.2-2-a Draft a Program Plan to . . .

- Explain your plans to others.
- Provide a record of where you began.
- Get a clear picture of the effort your program will require.

In breaking down your objectives to approaches, activities, and tasks, be realistic about your committee's capabilities. It is also important to budget time to raise money and obtain resources. For example, the following charts outline the task of holding a training session for health care professionals. They illustrate a good way to plan for all the details in a task while being realistic about your committee's capabilities or needs for additional funding and resources. Outlining each program's activities and tasks in this manner will provide your committee with a clearer picture of the effort that will be required. A blank version of these forms can be found in Appendix E. This chart will also be helpful later in your program, when you track the completion of your activities and tasks.

Example Activity/Task: Hold a training session on the benefits of folic acid for local health care provider association members. See Appendix I for a sample letter to a health care provider receiving a training kit, a slide-show presentation for health care providers, pre- and post-tests for the presentation audience, and contact information for other training kits already developed.

Components of Activity/Task:

- 1. Identify participants and logistics.**
- 2. Develop the presentation.**
- 3. Evaluate the presentation.**

The charts that follow break down the components of the activity listed above. Although these charts may seem to complicate a simple activity, they actually help you to think of and remember all the details. Any task can be broken down into smaller items and put into these charts. Every component has an evaluation measure to help you to feel confident that your activity will be successful. Although not all programs will have the time, try to chart as much as you can on the task list because your program is more likely to be successful if you do.

Table 1: Identifying Participants and Logistics

Planning Efforts	Person Responsible	Estimated Staff and Time Required	Resources Required
Identify local chapters of professional associations.	Staff	1 person approximately 4 hours and 1 week to hear replies	Telephone, e-mail, or fax expenses
Commit to a date and time.	Staff with input from the associations	1 person approximately 4 hours	N/A
Find a location for the training session.	Staff	1 person approximately 4 hours	In-kind donations for meeting space
Implementing Efforts			
Send out directions and agenda for training session.	Staff	1 person approximately 2 hours	Mail, e-mail, or fax expenses
Check to make sure all those who are attending received agenda and directions.	Staff	1 person approximately 1 hour	N/A
Set up refreshments to be served.	Staff	1 person approximately 0.5 hours	In-kind donations make this task inexpensive
Evaluating Efforts			

Table 2: Developing the Presentations

Planning Efforts	Person Responsible	Estimated Staff and Time Required	Resources Required	Date Completed
Conduct a needs assessment.	Staff with survey experience or training	Varies with collection and analysis activities: approximately 1 month	Mailing costs	
Locate/develop materials to educate professional organizations members and their patients.	Staff	1 or more people approximately 3 weeks	Design, writing, and printing costs. Can you obtain in-kind printing services or share materials already created by another organization?	
Pretest materials for health care providers.	Trained communicator	1 or more people approximately 1 month	Few to many depending on the type of pretest	
Find a dynamic and well-informed person to conduct the training session.	Staff with contacts to recruit a qualified speaker	1 person approximately 1 week	Volunteer presenters	
Implementing Efforts				
Make sure presenter has all needed materials.	Staff	1 person approximately 1 week	Phone and mail costs	
Print educational materials to be distributed to health care professionals.	Staff	1 person approximately 1 hour	Printing costs	
Evaluating Efforts				
Develop a brief survey of participants' knowledge and intention to educate patients about folic acid before and after training.	Trained communicator	Varies with collection and analysis activity: approximately 1 week	Varies. Can you use previously designed surveys or do you have to develop your own questionnaire?	
Record the number of requests for more materials or information	Staff	1 person	Cost of a telephone line	

Planning Efforts	Person Responsible	Estimated Staff and Time Required	Resources Required	Date Completed
Develop survey. (Step 4 will help you do this.)	Staff and trained statistician or researcher	1-2 people approximately 1 week	Costs could vary depending on the complexity of the survey; pro bono help can be found	
Test and revise survey.	Staff and trained statistician or researcher	2-4 people approximately 1-2 weeks	Few	
Identify and seek permission to survey sites and make sure they are representative of the health care providers who attended the presentation. (Step 4 will help you do this).	Staff	1 person approximately 2-4 hours	Knowledge of health care providers' offices and clinics in your community	
Gather staff to conduct survey and train them to ask the survey questions appropriately. (Step 4 will help you do this).	Staff, statistician, or researcher	1 person approximately 2 or more hours depending on the survey	Few	
Implementing Efforts				
Survey enough women at training sites before and after training session is given.	Staff	Depends on how many sites you go to, how many women you interview and how long the interview is	None	
Evaluating Efforts				

2.2-2-b Planning your program evaluation

The example above includes an evaluation to use in assessing the effectiveness of your **activity/task**. By interviewing clients (Step 3: Testing Your Messages and Materials) at health care providers' offices before and after the health care providers have been trained in counseling women about folic acid and given materials for educating them, you can measure whether the **activity/task** (training health care providers) has helped to incorporate folic acid education as a standard part of preventive health care services as outlined in your approach.

You will need to do another evaluation to assess the program's **objective**—whether more women increased their intake of folic acid daily. Both evaluations will provide you with valuable information. You should conduct an evaluation at multiple stages of a program—after each activity/task, as well as after your entire program has been implemented. Most prevention programs will have multiple activity/tasks and objectives to measure. Prevention programs measure the success of their activities/tasks to determine their intermediate progress. To determine their long-range progress, prevention programs measure their success in meeting their objectives. (Step 4: Deliver, Track, and Evaluate Your Program will help you to conduct these evaluations).

Please do not feel overwhelmed by doing multiple evaluations; some of these “evaluations” will simply be checking an item off a checklist. It is extremely important to assess your efforts at each stage. You will need to revise your plan if you find problems to make sure you keep on track and move toward your objective. (Step 4: Deliver, Track and Evaluate Your Program will provide you with a lot of tools that will make this process easy, such as examples of program evaluations and sample survey questions).

2.2-3 Determine How to Reach Your Audience

Following is a description of different ways you can reach people in your community. In Appendix H, you can find out more about working with the media. In Appendix I, you can find examples of news releases, PSAs, and other tools to use in the media. Please use or adapt any of the materials we have provided to suit the needs of your community effort.

MEDIA	BENEFITS	DRAWBACKS
Print	<ul style="list-style-type: none"> * Large reach; can be free or low cost * Information can be kept or shared * Works well with complex messages 	<ul style="list-style-type: none"> * Literacy requirements * Possibly low emotional appeal * Cost barrier
Newsletters	<ul style="list-style-type: none"> * Reaches opinion leaders: low cost * Message preservation high; responsive 	<ul style="list-style-type: none"> * Labor intensive; requires dedication * Possibly preaching to the converted
Radio	<ul style="list-style-type: none"> * Large reach; specific * Can be low cost or free * Interactive (e.g., phone-in shows) * Timely and repetitive * Possible use of celebrities * Possible access to creative team 	<ul style="list-style-type: none"> * No guarantee PSAs will be played * Staff discomfort with live interviews * No visuals * No control over placement (if free) * Can only reach a specific group (station dependent) * Limited to reception area of radio
Television	<ul style="list-style-type: none"> * Extensive reach; can be free * Different target groups reached * Possibly interactive, impact of visuals 	<ul style="list-style-type: none"> * Very expensive or limited to cable stations * High level of complexity possible * Not everywhere like radios (e.g., in cars)
Outdoor	<ul style="list-style-type: none"> * Wide reach * Can be inexpensive (e.g., posted flyers) * At times, captive audience (e.g., transit) * High message repetition and duration * Geographically focused * Visuals have great impact 	<ul style="list-style-type: none"> * Can be expensive (e.g., billboards) * Low specificity (e.g., may not reach specific audiences) * Short, simple messages only
Telephone	<ul style="list-style-type: none"> * Confidential; personal/private * Interactive; can follow up * Can direct efforts to specific groups * Inexpensive if a pre-taped response 	<ul style="list-style-type: none"> * Cost can be high (expensive & labor intensive if staffed) * Intrusive * Left up to individuals to call (if a hotline)
Mail	<ul style="list-style-type: none"> * Reaches a specific area (e.g., postal code) * Information can be kept; can follow-up * Appeals to a visual learner * If directed, 'named' individuals will read 	<ul style="list-style-type: none"> * Costs can be high * Can get lost (e.g. junk mail) * Misses low literacy groups * Can create negative associations
Point of Purchase	<ul style="list-style-type: none"> * Timely; immediate reinforcement * Can be interactive (e.g., demonstrations) * Information where it is needed; effective targeting * Good opportunity for partnering 	<ul style="list-style-type: none"> * Relatively small reach * Loses effectiveness over time/need to change * May discriminate against women of low socio-economic status * Difficult to partner if controversial * Depends on others to get the message out

Computer-Based Publicity

- * Large reach but select audience
- * Interactive
- * More youth friendly
- * Can control information received (e.g., CD Rom)

- * Select audiences; literacy barrier
- * High cost for equipment
- * Requires skills and training
- * If on CD-Rom cannot easily update

FACE-TO-FACE

BENEFITS

DRAWBACKS

Presentations

- * Interactive
- * Specific & captive audience
- * Information can be timely

Training

- * Reaches specific audience
- * Strong multiplicative power
- * Can build skills; peer to peer support
- * Interactive

- * Attendance may be “forced,” resulting in low motivation.
- * Different learning styles and knowledge levels.
- * Limited to one-on-one consultation

Informal Networks

- * Interactive; specific
- * Comfort of cultural similarities, small group (e.g., familiar, safe)
- * May encourage work at societal levels, etc. or in other areas of life
- * Provides access to other networks

- * Information can be biased or unreliable
- * Focus on experience may be narrow
- * Requires a certain personality
- * Can be clique-ish, exclusive
- * Limited, homogenous group

EVENTS

BENEFITS

DRAWBACKS

Community-Wide

- * Large reach
- * Interactive and fun
- * High visibility; high level of interest

- * Difficult to follow-up and evaluate
- * Cannot tailor to a specific group/public
- * Labor and resource intensive

Specific Group

- * Captive audience
- * Provides immediate feedback
- * Evaluation easier; cost benefit relationship possible

- * Narrow focus; reaches only a few
- * Higher cost to reach fewer individuals
- * Labor intensive (time); low visibility
- * No spillover to other communities
- * Special needs requirements

A large empty rectangular box with a smaller empty rectangular box centered inside it, intended for notes or additional information.

2.3. Identify the Timetable and Program Costs

2.3-1 Use a Timetable

A timetable will help you to complete program efforts on time, help remind others of their responsibilities and commitments, and hold the expectations of the group together. Ideally, it will assist you in projecting costs accurately and completing a successful campaign. Every activity and corresponding task you outline will be included in the timetable. Following is a detailed sample timetable format from Onondaga County, New York. Your efforts may be larger or smaller than the ones accomplished by Onondaga County.

2.3-2 Estimate the Costs of Each Activity or Task

Activities and task costs of small and big budget folic acid programs conducted in the United States are in Appendix E. Of course, your costs may differ somewhat. Estimate your funding needs with input from your committee members.

2.4. Locate Funding Sources

2.4-1 Identify Your Available Resources

- What resources have you used for past or current projects?
- What untapped, or previously unused, resources do you possess?

Specifically, identify what resources you have in the following areas:

Money. Yours and that of partners.

Labor. This includes the labor of staff, volunteers, local students, and interns. Volunteers, students, and interns are usually talented and interested in enhancing their resumes with meaningful work. One idea is to hold a contest at a local art school for the designer of your campaign logo.

Contacts. These may be political, professional, or personal.

Technology. For example, computer software such as Power Point® to create your own slide show or graphics.

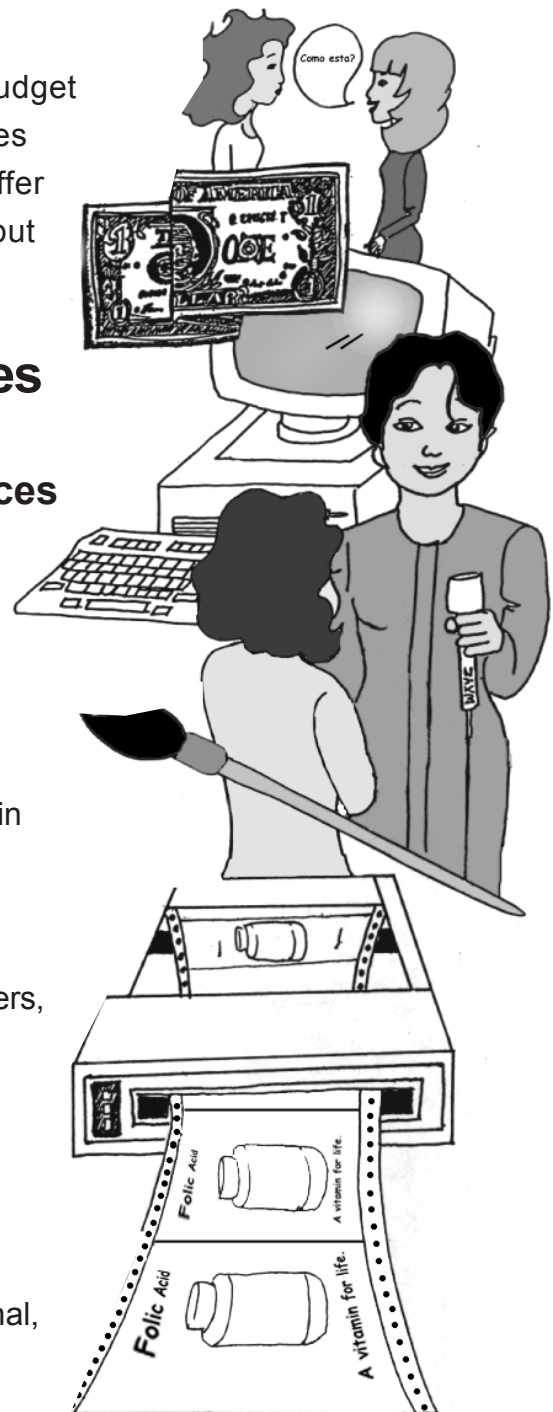

Skills. For example, people who know how to use computer programs or multilingual people able to teach others about the benefits of folic acid.

Production mechanisms. For example, a high-quality color copier that could reduce demands for a professional printer.

Channels. For example, newsletters.

Creativity. For example, people in your organization who can design your campaign logo or paint it on banners.

2.4-2 Identify Where Your Resources Fall Short

- First, identify your committee's abilities to implement your program plan. Check your program plan, timetable, and projected costs. Do not limit this identification process to money; for example, you may need expertise or political influence not found in your organization.
- Then do the same with the resources found in your community, especially those of your potential partners.

2.4-3 Determine What You and Your Partners Can Do Together

Your partners will play a key role in saving money and maximizing your program's impact. Here are some tips for containing costs:

2.4-3-a Share resources

“Resources” include information, technology, funds, program elements, and staff. You can exchange in-kind services by sharing staff members and their skills. For example, your resident “graphic artist” can help a partner design a logo in exchange for access to a computer program that will enhance computer images. See Appendix E for instructions on how to use “camera-ready materials.” These are reproducible materials, ready to be duplicated, that have been created by another group that is willing to share them with you. Camera-ready materials photocopy well and will save you the expense of developing your own materials. CDC provides tested messages and materials ready for you to use and adapt.

2.4-3-b Hold joint training sessions

If your organization needs to learn a computer skill, for example, try to find another organization in the community that has already planned a training session and split the costs with them. If you would like to educate your organization about folic acid and its benefits, find other organizations in the community that might be interested in or benefit from learning about this issue. Split the costs of a location and an expert speaker with the other group.

2.4-3-c Coordinate health messages that have a common goal or suit each other well

Community members such as school health teachers, who may already promote calcium to young women, could also promote folic acid. The message could state, “Take a multivitamin because folic acid and calcium are good for your health.” Similar advantageous opportunities exist with other public health messages like the “Five-A-Day” campaign to fight cancer. This strategy is a good option for those communities especially low on resources. If you have the resources, however, do not send out combined health messages. Too much information can dilute the power of the message and increase the chances that women may not hear or remember about folic acid.

2.4-3-d Use creative techniques

For example, one community nonprofit organization with limited funds built a portable folic acid poster and display board that allowed presentations to be tailored to suit the audience or event. Users could change the text displayed through flip charts and rearrange images in the presentation by attaching them with Velcro[®]. This penny-wise exhibit has traveled around the county and assisted many different programs in getting their folic acid messages out.

2.4-3-e Find in-kind support

Although you and your partners should be able to exchange staff skills, you should also seek outside in-kind donations. Assistance can come in the form of labor, materials, and expertise from advisory groups and industry. In one state, an advertising agency did *pro bono* work. Then a local radio station taped a PSA (public service announcement) for the state’s “News Network,” which sent the PSA to 99 other radio stations! You should brainstorm a list of groups like advertising agencies and news networks that could make contributions to your campaign. Newspapers can donate community pages for your advertisements. Nutrition stores, grocers, and pharmacies can donate folic acid supplements for press kits or health fair give-aways. Hotels, schools, and convention centers can donate meeting space. Appendix H describes different media channels, showcases one campaign’s media ideas and costs, and lists way to develop your own media tools. Appendix I provides you with other folic acid promotion programs’ tools that you can use and adapt.

2.4-3-f Do your research together

In addition to testing program ideas and concepts with the target audience, programs need to test their messages. Step 3, “Testing Your Messages and Materials,” tells you how to test these messages. In Virginia, partnering made audience research, concept development, and material testing easier. Many campaign partners communicated daily with childbearing age women. These partners were able to provide enough information (basic audience research) about women in the community to select and group campaign

messages most effectively. Campaign partners also recruited participants for focus group research, cutting down on the costs of organizing and conducting focus groups to develop concepts and test messages and materials.

2.4-4 Apply for Grants

In 1992, according to “Foundation Giving,” \$18.8 billion in foundation grant money was distributed for education and \$13.9 billion was distributed for health-related purposes. A folic acid educational program could qualify for either category of grant money. Appendix E provides you with information about foundations and grants that may be available to you. If you decide to pursue foundation money, consult with someone in the granting agency about what the agency needs from grant applicants and what your chances are for success. Do not spend a lot of energy pursuing funds that are very competitive—it is better to go to local businesses for specific or in-kind donations.

2. 4-5 Identify Sources of Money and In-Kind Services

Here are a few suggestions for sources of money and in-kind contributions:

- **The governor's office in your state**
- **Your state health department**
- **Other governmental agencies**
- **March of Dimes**
- **Foundations for women's and children's wellness**
- **CDC-funded national regional minority organizations**
These organizations provide technical assistance to community-based organizations to help with coalition building and other activities.
- **Private corporations**
- **Omnibus survey** Various manufacturing companies combine their resources to research information about consumers. Any corporation that advertises to women may be willing to share its market research with you. Feminine hygiene, multivitamin, hosiery, cosmetics, contraceptive, and clothing companies are some of the corporations that advertise to women.
- **Corporate philanthropic departments** Many large corporations set aside funds to be donated to charitable organizations or events. A folic acid campaign certainly qualifies. A corporation in your community stands to gain a lot by supporting such a positive, noncontroversial public health issue. One program was successful in having General Electric accept its proposal to fund the printing costs of a transit advertising campaign. In Appendix E, you can find more information about finding corporate sponsors.

- **Money matching programs** Many private foundations, corporations, and organizations allocate matching funds. One state raised \$1,740 and then received a money match of \$1,740 from Medicaid. The amount of matching funds varies. Sometimes, an organization or company will place a limit on the total amount of money it will give to your program. In all instances, you can solicit many organizations to participate.

2.4-6 Consider Final Items

- If you have not yet found a funding source for an activity, you should search among your partners for in-kind services to cover it.
- Consider successful fund-raisers your partners may have held in the past. Or, ask a local company to designate your folic acid program as this year's beneficiary of its fund-raising activities.
- Add or delete activities from your program plan and timetable to reflect the results of your partners' abilities and contributions.
- Form a final program plan and timetable with all your new information and contacts. Continue using the prepared program planning charts in Appendix E.
- Ensure that community partners can maintain activities when program funding runs out. Partners who have helped guide the project can also be the nucleus of a lasting coalition to continue folic acid prevention activities. Recruit your partners with this in mind. Share your knowledge about folic acid and partners will allow their roles in the campaign to grow over time.

Step 3: Test Your Messages and Materials

Step 3 will help you to:

- Create compelling messages and materials.
- Learn how to test messages and use the results.
- Gain support from community leaders.

3.1 Create Message(s) for Your Intended Audience

Now the fun begins! It is time to create or adapt the messages and means for reaching your audience(s). You have a lot of great information to develop some interesting, appealing, and compelling messages for each group of women you want to reach. If you are not creative by nature, then you will want to approach people in your community who are creative—art students or teachers, advertising agency personnel, marketers, and theater participants, for example. You should use the information that you have gathered to develop a message that appeals to your audience and motivates them to meet your objectives. To supplement your effort, the CDC has tested messages and materials are available free of charge. These messages and materials have been tested for English- and Spanish-speaking groups of women intending to get pregnant soon, and those not planning a pregnancy. You are welcome to take these messages and materials and adapt them to your organization's and target audience's needs. For more information, call CDC's Birth Defects and Developmental Disabilities Division at 1-800-CDC-INFO (232-4636) or e-mail flo@cdc.gov for more health communication information.

3.2 Test Your Ideas With the Intended Audience

Create “mock-ups” or samples of your message, including the text and pictures, and show them to partners and members of your audience. Ask them to give you specific feedback on what you show them and listen to their comments. It can be hard not to be defensive about your creation, but it is important to listen and probe members of the target audience to understand which elements of your message work and which ones do not—and why. If you think you cannot do this objectively, find someone else to do it for you.

You can *pretest* your messages among members of your intended audience in a number of ways, including *self-administered questionnaires*, *in-depth interviews*, *central-location intercept interviews* (e.g., in a mall), *focus group interviews* and *theater tests*. All of these methods have the same goal: to obtain reactions to your materials. The methods differ as to where you gather this information and whether reactions are obtained from individuals or groups.

Materials in a language other than English should be tested with speakers of that language. It is important to test the message and materials for language usage and to make sure they are culturally appropriate and relevant. Be sure there are no mistakes in materials written in other languages. See Appendix B for additional information on creating and testing culturally effective health messages.

MATCHING A PRETESTING METHOD TO YOUR NEEDS							
	Readability Test	Focus Individual	Individual Interviews	Central Location Interviews	Mail Questionnaires	Theater Tests	
1. Concept Development		X		X			
2. Poster	X	X	X				
3. Flyer	X	X	X	X	X		
4. Booklet	X	X	X	X	X		
5. Notification Letter	X	X	X	X	X		
6. Storyboard		X		X			
7. Radio PSA		X		X		X	
8. TV PSA		X		X		X	
9. Videotape		X		X		X	

The following table provides a summary and the pros & cons of each testing method:

Pretest Method	Description	Pros	Cons
<p><u>SELF-ADMINISTERED QUESTIONNAIRE</u></p> <p>Minimum of 20 respondents (100 to 200 is ideal)</p> <p><u>Resources needed</u></p> <p>List of potential respondents, questionnaire, analysis expertise, postage if necessary</p>	<p>Individual audience members review draft materials and complete a questionnaire pertaining to the materials.</p>	<ul style="list-style-type: none"> * Inexpensive (does not require staff time to interact with people) * Anonymous * Accessible (can reach homebound, rural, other difficult-to-reach groups) * Easy and usually quick for respondents * Flexible (respondents can do at their own pace and at a convenient time) 	<ul style="list-style-type: none"> * Response rate may be low (if mailed) * May require follow-up * May take too long to receive sufficient responses * Respondents choose to respond, leaving out those who do not want to take the survey room for a potential bias * Does not control how a respondent sees and interacts with the materials, which may lead to respondents giving answers that would be different in other viewing circumstances * May not be appropriate if audience has limited writing skills
<p><u>IN-DEPTH INTERVIEWS</u></p> <p>At least 10 respondents per group of women</p> <p><u>Resources needed</u></p> <p>List of potential respondents, possibly money to pay to interviewees, trained interviewer, telephone or quiet room, tape recorder, analysis expertise</p>	<p>Individual audience members review draft materials and are asked questions about them in an in-depth, face-to-face interview.</p>	<ul style="list-style-type: none"> * In-depth response may differ from first response * Can test sensitive or emotional materials * Can test longer, more complex materials * Can learn more about “hard to reach” audiences * Can be used with individuals who have limited reading and writing skills 	<ul style="list-style-type: none"> * Can be time consuming to conduct and analyze * May yield no patterns in responses, especially if number of interviews is limited * Incentive gifts may be needed

Pretest Method	Description	Pros	Cons
<p><u>CENTRAL-LOCATION INTERCEPT INTERVIEWS</u></p> <p>Sixty to 100 interviews per target audience</p> <p><u>Resources needed</u> Trained interviewers, questionnaire, analysis expertise, access to a central location, quiet spot for the interview</p>	<p>Individual audience members review draft materials and are asked a few questions in a brief interview in a public place (for example, malls and stores.)</p>	<ul style="list-style-type: none"> * Can quickly conduct a large number of interviews and analyze closed-end responses * Can be inexpensive * Can test many kinds of materials * Can be designed to provide reliable information for decision making 	<ul style="list-style-type: none"> * Cannot provide in-depth answers or probe sensitive issues * Participants may need incentives * Sample is restricted to individuals at a location * Respondents that choose to cooperate may not be representative
<p><u>FOCUS GROUPS</u></p> <p>Eight to 12 people per group, at least two groups per type of respondents</p> <p><u>Resources needed</u> Four to 6 weeks planning time, incentives for each focus group, trained moderator, discussion outline, meeting room, food, recording equipment, analysis expertise</p>	<p>A small group of audience members review draft materials and are asked a series of probing questions which the group discusses together.</p>	<ul style="list-style-type: none"> * Can provide many in-depth opinions about one or many issues, concepts, or materials * Can trigger creative thinking 	<ul style="list-style-type: none"> * Responses may be influenced by the opinions of others in the group * Cannot probe sensitive or complex questions * Cannot provide statistical data for consensus and decision making * Need gift initiative * Should provide food (snacks and beverages)

Pretest Method	Description	Pros	Cons
<p><u>THEATER TESTS</u></p> <p>Sixty to 100 respondents per target audience</p> <p><u>Resources needed</u></p> <p>Large room, incentives for participants, questionnaire, analysis expertise, list of potential respondents, possibly audio/ video equipment</p>	<p>A large group of audience members reviews draft materials, which are embedded into other materials, and are asked to respond to brief written surveys.</p>	<p>* Can test a large group inexpensively at once and analyze the data fairly quickly</p> <p>* Can simulate natural exposure to materials and help gauge how they compete with other messages</p>	<p>* Can be time-consuming to arrange</p> <p>* Can be expensive</p>

To get useful results from pretesting, you must plan carefully. Ample time should be scheduled for the following:

- Contract with research firms (if necessary).
- Arrange for the required facilities (1-2 weeks).
- Develop and test the questionnaire (2-3 weeks).
- Recruit interviewers and respondents (2-4 weeks).
- Gather the data (1-2 weeks).
- Analyze the results (1 week).
- Make appropriate changes in messages or materials.
- Pretest again, if needed.

Appendix B presents several references that provide detailed instructions on the focus group process, including how much a focus group costs, how to develop a guide for focus group moderators, and how to recruit participants. Also listed are contacts in other states who have done focus group testing for their own folic acid prevention programs. In addition, Appendix B contains references that detail other types of pretesting methods and includes some easy-to-read writing tips and the SMOG readability test to use in determining the reading levels of your materials. Remember to have fun doing this—you have a great opportunity to learn from audience members about what is important to them and what may influence their behavior.

3. 3 Use Pretesting Results to Improve Your Materials

3. 3-1 Look for Recurring Themes in What People Say

Find out what they like or do not like about the materials, what they would change, and any suggestions they offer. Do not try to quantify the results of your pretesting (for example, counting the number of people who said “I like this or that”), and do not feel you have to respond to every single comment.

3. 3-2 List Recurring Themes and Relate Them to the Materials

Group responses together, and try to describe the underlying idea behind the response groups. You can even “name” the groups of responses to help you remember what that underlying idea is. For example, in one pretest of materials, many respondents said that they were confused about 400 mcg. versus 0.4 mg. versus one multivitamin pill. Researchers titled this theme “Dosage Confusion” and chose to use the least confusing term for their materials: one multivitamin pill.



3. 3-3 Adapt Your Materials, Incorporating the Major Themes

Pretesting with the target audience told one group that its program message was too complex and the vocabulary level too high. The group then changed its brochure to read at the sixth-grade level. You can use the SMOG readability tests provided for you in Appendix B, or other tests.

Partnering Tip

A great community resource that is often overlooked for doing audience surveys is community adult-education programs. Students in these classes can often provide helpful feedback.

3. 3-4 Pretest Your New Drafts

If you have time and resources, take your revised draft back to your intended audience for a second review. If you use the same group of people, they will be encouraged to see that you really listened to them. The following is an example from a WIC organization that created and tested audience-appropriate messages and materials for a folic acid promotion event.

Real World Examples

A community WIC office wanted to run a local media campaign related to folic acid for Mother's Day. Women who use WIC's services in this community are, in general, of low income levels, between ages 19 and 29, less educated, and unlikely to know enough about nutrition and vitamin supplementation to consume the recommended levels of folic acid. The WIC staff thought that their clients were also unlikely to be interested in seeking out information about health and nutrition or to think it was very important for themselves (as opposed to being important for their children).

The staff asked a random group of clients about their radio and television viewing and newspaper reading habits. Television was overwhelmingly the primary source of information for the group. WIC staff also questioned some of the women about their knowledge, attitudes, beliefs, and behaviors about vitamins and folic acid. Most of the women did not know about folic acid and were not interested in taking vitamins. They did not buy vitamins very often, and if they did, it was mainly for their children. They also reported believing that they did not need vitamins for themselves and that they did not like taking pills. Only 18% reported taking vitamins one or more times per week (less than the national average of 26 to 30%). They did talk about how important their children's health was to them, however.

As a result of this information, the WIC staff decided to pursue a Mother's Day campaign message that would emphasize the importance of a mother taking folic acid supplements for her children's sake. To cater to their client's media habits and sources of knowledge, they sent the message out through a PSA that could be aired around Mother's Day on the local television stations during the daytime soaps and talk shows.

3.4 Show Your Revised Message to Important Gatekeepers

Gatekeepers are people who control or influence whether the intended audience ever receives your materials. They can be internal or external. Internal gatekeepers are from the agency in which you work. External gatekeepers are people from outside your agency. External gatekeepers include people who either interact directly with audience members (for example, health care providers) or directly influence what information audience members receive (for example, program managers at radio or TV stations). The following lists three important actions to take when obtaining gatekeepers' approval of your program materials.

- You should show gatekeepers your draft materials and incorporate their feedback before producing your final materials. By doing so, you are acknowledging their influence on your audience which is likely to solidify their support, and also you are alerting them about what you will be needing from them in the future.
- It is very important to show gatekeepers your audience research and pretesting results along with your messages and materials. Gatekeepers may initially not like the materials you present but may be convinced to use them if shown your audience research and pretesting results. With your audience research and pretesting results, you can explain why the messages and materials you developed are likely to be effective.
- Most agencies have a “clearance” process, whereby materials are reviewed before they are printed and distributed to the public. Some basic elements of a review process include ensuring the accuracy of information and the appeal of the layout and design. Every agency's clearance process has different standards and time requirements by which materials are reviewed. Know these rules in advance so you can plan better.

Step 4: Deliver, Track, and Evaluate Your Program

Step 4 will help you to:

- Kick off your program with grace.
- Keep track of events and new participants.
- Prepare to make necessary changes in the program.
- Evaluate your program's success.

4.1 Kick Off Your Program

By this time, your program staff and committee should be ready. You have all the resources you need and a timetable to put everything together. Although you may be tempted to “just do it” once you have reached this stage, your campaign will run more smoothly if tasks are specifically outlined. As campaigns proceed, unanticipated opportunities for message dissemination are often generated. The Puerto Rico campaign, for example, prompted two health insurance companies to provide training on folic acid for their primary care physicians after the campaign was under way. The following ideas will help you to keep organized and adapt to additional demands.

4. 1-1 Make Checklist for Activities

Checklists are excellent tools with which to make sure you are ready to implement an activity. The program planning charts provided in Appendix E can be used to track your accomplishments. In writing checklists, you should consider the details of each activity. Your checklist will help you determine if your program is ready to be launched. A sample checklist follows. Questions for the checklist will vary from program to program, depending on the activities you choose. Another sample checklist for a program’s partner can be found in Appendix F.

Checklist

Have you reminded all of your partners that you are counting on them to carry out their assignments?

Do they know when, where, and how to do their activities?

Do you have a list of media, businesses, and organizations to contact?

Are the materials ready in sufficient quantities?

Have those involved in your program been trained properly?

Are physicians and other health care professionals ready to answer questions and to provide materials about folic acid to their patients?

Are PSAs, press kits, inserts, brochures and other materials ready to be distributed and received by the media?

Are the materials ready for volunteers and their organizations to begin their activities?

Have you called the media to remind them of important dates?

Have you followed up with each volunteer and volunteer organization to remind them of important dates and commitments and to check on materials and problems?

Are you prepared to work with intermediaries who volunteer after the program has been implemented?

Are you prepared to ensure that each activity is happening as you planned?

Do you have follow-up response cards and thank you letters ready?

Do you have plans for a newsletter, meetings, or other methods to keep partners updated and involved?

Do you have a celebration for your accomplishments planned and ready?

4. 1-2 Prepare Packets

Activity packets can be prepared in advance to respond to new requests by the media, potential funders, or new partners. These packets would be designed to orient your new partners to the campaign. A cover letter, a program activity list, and a brochure are essential in each packet. The other activity packet items will depend on the type of partner who offers their support. For instance, an NTD prevention slide presentation or informational speech could be included for health care providers or teachers. PSAs and photos could be included for media partners. Having these packets prepared *before* they are needed will free up your time to respond and to incorporate new community contributions, deal with unexpected opportunities, and impress your community partners with your commitment to the campaign. To prepare the packets, you could even have a “packing party” with some of your partners or volunteers.

Partnering Tip

- *Provide partners with a series of small, short-term tasks and frequent “thank you’s” or small rewards like certificates of appreciation. Do not give partners too much to do at once.*
- *Use communication channels such as newsletters, e-mails, meetings, or milestone parties to update and inform partners about the program’s progress, achievements, changes, and important decisions.*



Real World Examples

A large, empty rounded rectangular box intended for writing real-world examples.

Media Campaign

Tips:

- Kick off your campaign during a proclaimed month or date such as Spina Bifida Awareness Month. A nationally recognized event adds to your message promoting folic acid. A list of other timely opportunities to promote the use of folic acid is in Step 2.
- Contact your local Spina Bifida Association for spokespersons. With prior approval, a local family affected by spina bifida may be included on a list given to the media of people who would be available to give interviews.
- Include folic acid supplements. This gift will make your press kit unique and memorable, thus adding to your response. You may be able to have these donated by a local store or pharmacy company.
- Provide informative articles that can be inserted into a newspaper and 30-second and 10-second public service announcements for radio stations.
- Make sure your information is correct and up-to-date. Have a knowledgeable editor for your material.
- Be brief, and know who the contact person is at each newspaper and radio station.
- Follow up with a letter or phone call.
- Keep the message simple so that the newspapers and radio stations will feel confident displaying the information to the public.

Press Kit Includes:

- Cover letter
- Press release
- Folic acid information
- Information on partners and their services
- Short article prepared for print
- Public service announcements for radio
- Follow-up letter to radio stations
- Response cards for newspapers and radio stations to mail back
- Samples of newspaper articles

Appendix H can help you to develop your own press kit for the media.

4. 1-3 Train Partners and Volunteers

To ensure that everyone involved is providing the same message, you need to spend time educating your partners and volunteers about the importance of women of childbearing age consuming 400 micrograms of folic acid daily. Health care providers need reviews and updates too. Everyone should feel comfortable before beginning the tasks for which they volunteered. In Appendix I, you will find a cover letter for health care professionals, a training kit/slide show presentation, and how to contact other programs that have prepared training kits.

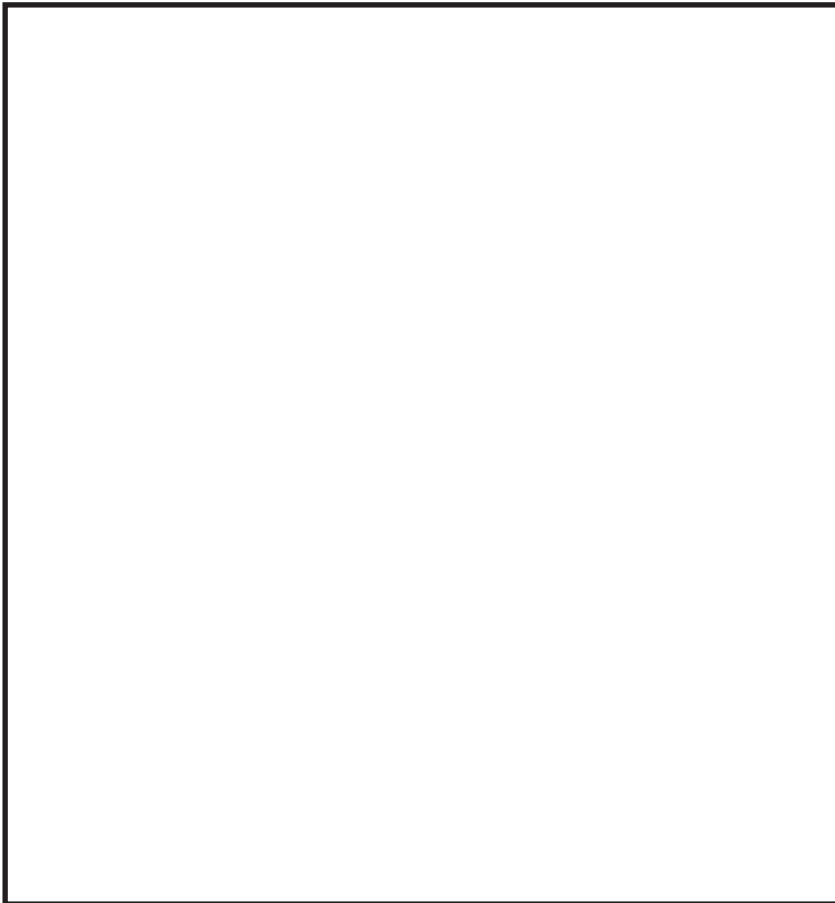

4.2 Keep Track of Your Program

Every plan needs a mechanism for checking on the progress of activities. This mechanism, called *process evaluation*, allows you to detect small problems before they become big ones, provides a realistic basis for mid-course decisions, and can give participants some preliminary encouragement if it reveals evidence of success. Process evaluation may also lead you to replace procedures that are not working well with more effective ones. You should establish some specific time intervals for reviewing the progress of your program. At these intervals, measure activities and outcomes that relate to the goals and objectives of your program. Some questions to answer include the following:

How well did you plan?

- Are activities on track?
- Are time schedules being met?
- Are resource expenditures acceptable?
- Is staffing sufficient to meet program needs?

How are individual activities progressing?

- What activity has been done?
- How many times has it been done?
- Who did the activity?
- Who was the intended audience?
- How big was the intended audience?
- How long did the activity last?
- Was the timing of the activity appropriate?
- Was the location a good one for reaching your audience?

Is the intended audience being reached?

- How many people in the target audience were reached by electronic media?
- How many were reached by print media?
- How many sets of educational materials were distributed?
- How many presentations were given and what percentage of your target audience was reached through these presentations?

Are people responding?

- How many inquiries were made by mail, by telephone, or in person in response to your campaign?
- How many intermediaries volunteered after the campaign began?

Are there any problems or issues that need to be worked out?

- Do some aspects of the program need more attention? Do some need to be changed or eliminated?
- Can you improve the delivery of services for the remainder of the program?

Partnering Tip

Remember that all participants in your campaign need to know that what they are doing is important and appreciated. Take time to celebrate your accomplishments and acknowledge the contributions of everyone. Be sure to think about how you want to share information about accomplishments and about how you want to celebrate those accomplishments.

Thank-you letters, certificates of appreciation, a celebration luncheon or party, or acknowledgments of a job well done will motivate people to keep working on the plan. Even bringing cookies, fruit, or drinks to a long meeting can help provide a positive atmosphere. Celebrating your short-term successes and showing appreciation for your partners will help your efforts for the long term.

Real World Examples

A large, empty rounded rectangular box with a thick black border, occupying most of the page. It is intended for providing real-world examples related to the topic of preventing neural tube birth defects.

4.3 Evaluate Your Program Effects

In measuring the success of your folic acid program, you will want to know if you are making a difference. Activities that help you measure the effects of your prevention efforts are called *outcome evaluation*. In the previous section, you read about the benefits of monitoring your program's activities. That type of evaluation, process evaluation, answers the question, "Is the program working as expected?" If not, "What can we do about it?" By measuring the end results of a project, you can answer the question, "How well did the program work or achieve its objectives and goals?"

Why should you do outcome evaluation?

- It demonstrates the results of your project's efforts to partners, advisors, staff, or populations that you tried to reach.
- These results can provide evidence of a need for additional funding, resources, or activities.
- The results can be used to improve and revise an ongoing program.
- The results may encourage others to initiate and maintain public health prevention efforts.

4. 3-1 Review Your Program's Goals, Objectives, and Resources

This section will help you to assess what kind of evaluation would be most beneficial to your program.

4. 3-1-a Evaluate your program's objectives

If you wrote measurable objectives, this task will be very straightforward. If you did not, evaluation may be difficult. Measurable objectives can include changes in knowledge, attitudes, or behaviors. For instance:

- Compare the percentage of women who knew about the importance of folic acid before and after the program.
- Compare the percentage of women who used vitamins containing folic acid before and after the program.
- Determine the percentage of women who increased their consumption of foods fortified with folic acid and rich in folate since the beginning of your program.

4. 3-1-b Think about your resources

Measuring the effects of your program takes time and money. In designing your evaluation, think about the personnel, time, computer facilities, and funds available to you as well as your agency's policies and any previous, well-designed evaluation activities that you know of to use as a model. The resources available to you will determine the type and extent of evaluation that can be done.

4.3-1-c Identify an appropriate evaluator

You have two basic choices—in-house staff or outside consultants (experts from research organizations). If you are new at measuring effects, consider getting some outside help, either training or technical assistance. In measuring effects, there are many complicated issues to grapple with such as bias, cost, skills, politics, resources, and time

PROS

In-House Staff

- Less Costly
- Familiar with product

Outside Consultants

- Evaluation expertise
- Fresh outlook
- Increased credibility
- More objective

CONS

- Difficult to be objective
- Usually less evaluation expertise

- More costly
- Have to inform about project specifics
- Effort to find competent evaluator

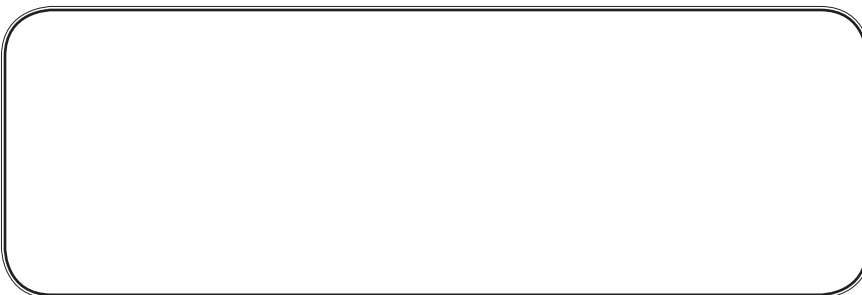

4. 3-1-d Define the purpose of the evaluation

Think about what the evaluation results might accomplish and who needs to be aware of the results.

- What changes do you want to measure?
- What do funders want to know?
- What does the staff or program director in your program want to know?
- Should you continue or discontinue the program?
- How can you improve the program's practices and procedures?
- Should you add or drop specific program activities?
- Can or should similar programs be instituted elsewhere?
- Are your results useful to people in other geographic locations, to other groups of women, or to other programs?

4.3-2 Decide How to Measure Your Results

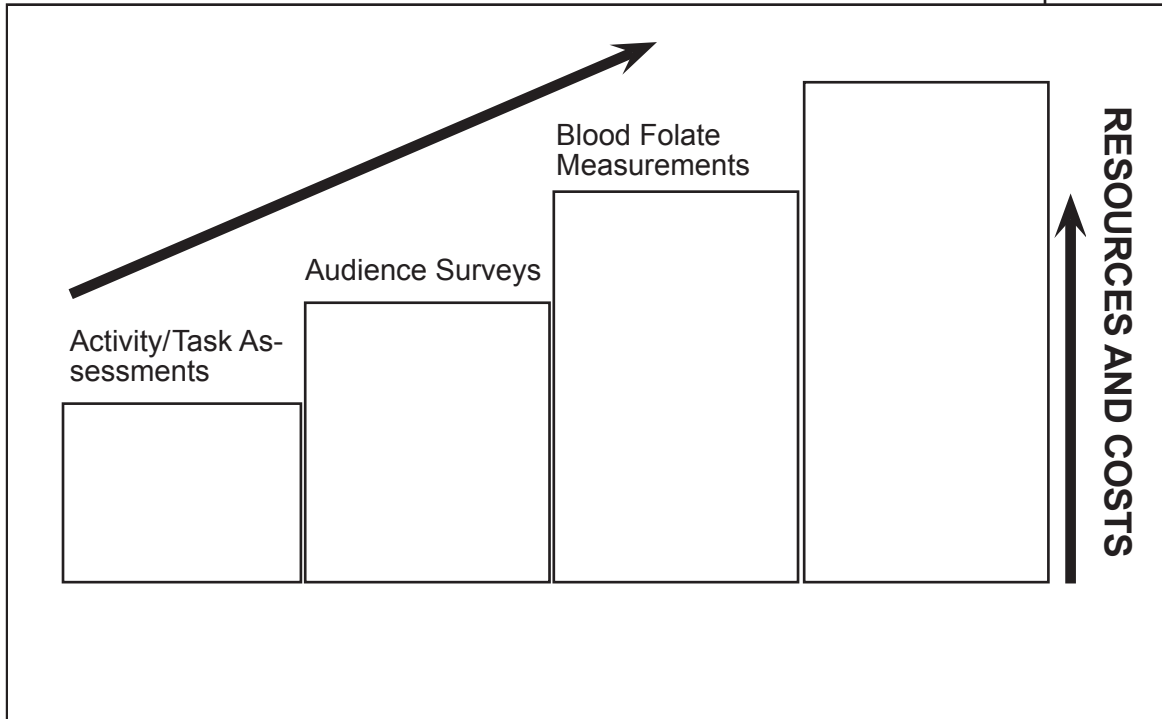

The following are examples of ways to measure your program's accomplishments. These accomplishments can be activities, as well as results of those activities. Measurements range from simple ones that require few resources to complex ones that require more.

4. 3-2-a Activity/Task Assessments

These types of measurements do not inform you about your target audience's changes in knowledge, attitudes or behavior. Instead, they are used to measure how effective you have been in getting your message to your target audience. For example, you might count:

- The number of houses visited on a door-to-door folic acid awareness campaign.
- The number of people attending educational events.
- The number of folic acid brochures distributed in a clinic.
- The number of articles on folic acid published in newspapers and employee newsletters.
- The number of supplements distributed to, or purchased by employees at a workplace.
- The number of responses to your activities. (For example, responses to a PSA or press release, or requests for information to a toll-free number).

Activity/Task Assessment Tip

One way to enhance your activity/task assessment would be to find out more about the women who respond to specific messages. Counts or estimates of the number of women that you reached in specific geographic, ethnic, and age categories would be helpful for further measuring the results of your program.

Real World Examples

A New Mexico program sent out a comprehensive press kit to television and radio stations and newspapers that included a press release with a toll-free telephone number. The staff counted telephone calls to this telephone line as a way to track the responses to its public awareness campaign. They also counted calls to the program's telephone line and requests for materials.

Benefits

- * At a minimum, provides a quantifiable measure of activities or a community's "exposure" to a message.*
- * Less costly and less resource intensive than other evaluation activities.*
- * Results are easily understandable.*

Drawbacks

- * Measures the activities, not the ultimate behavior change or outcomes. For example, the fact that 300 brochures were distributed at a clinic does not mean that they were read. Similarly, the fact that 500 bottles of folic acid supplements were distributed at a workplace does not necessarily mean that the women took them.*
- * Could require cooperation of partners like pharmacies and grocery stores to track measures like sales.*

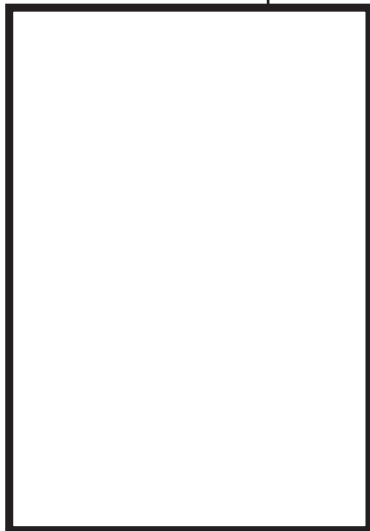
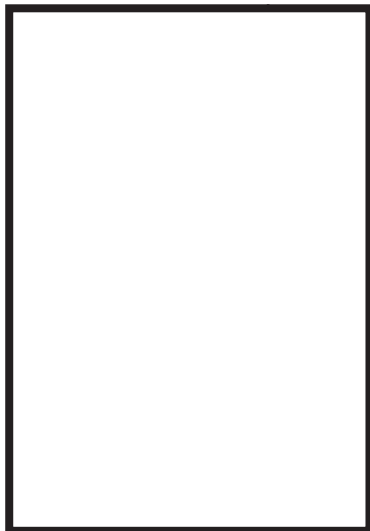

4. 3-2-b Measure changes in women’s knowledge, attitudes, and behavior

An evaluation taken before and after a program can be very useful in demonstrating the effectiveness of your program. A survey is one method many folic acid programs have used in the past. However, designing a reliable survey is not easy. Without experienced and careful survey design and sample selection, results from surveys can be misleading and inaccurate. Appendix G contains survey questions that have been used by CDC and others. We encourage you to use these questions. If you use the same questions as those asked by other programs or in other areas, your results can be compared with theirs. Please note that these questions may not address a community’s specific cultural, racial or ethnic, linguistic, economic, or other characteristics. Contact a university statistician or social science researcher for help in tailoring these questions to your community’s needs.

To measure changes in women's behavior, folic acid promotion programs could also track the sales of folic acid-containing vitamins, foods fortified with folic acid, or foods rich in folate. Examples are:

- A managed care organization could track multivitamin and folic acid supplement sales in their in-house or contracted pharmacies before and after a folic acid educational campaign.
- A program could ask a pharmacy chain that serves its target population to track multivitamin and folic acid sales before and after a folic acid educational campaign.
- A program could ask a grocery store chain to monitor the sales performance of orange juice and fortified breakfast cereals like *Product 19*[®], *Total*[®], *Multigrain Cheerios Plus*[®], or *Smart Start*[®] before and after a folic acid educational campaign.

Real World Examples

A large, empty rounded rectangular box with a thick black border, intended for taking notes or providing examples. The box is currently blank.

Real World Examples

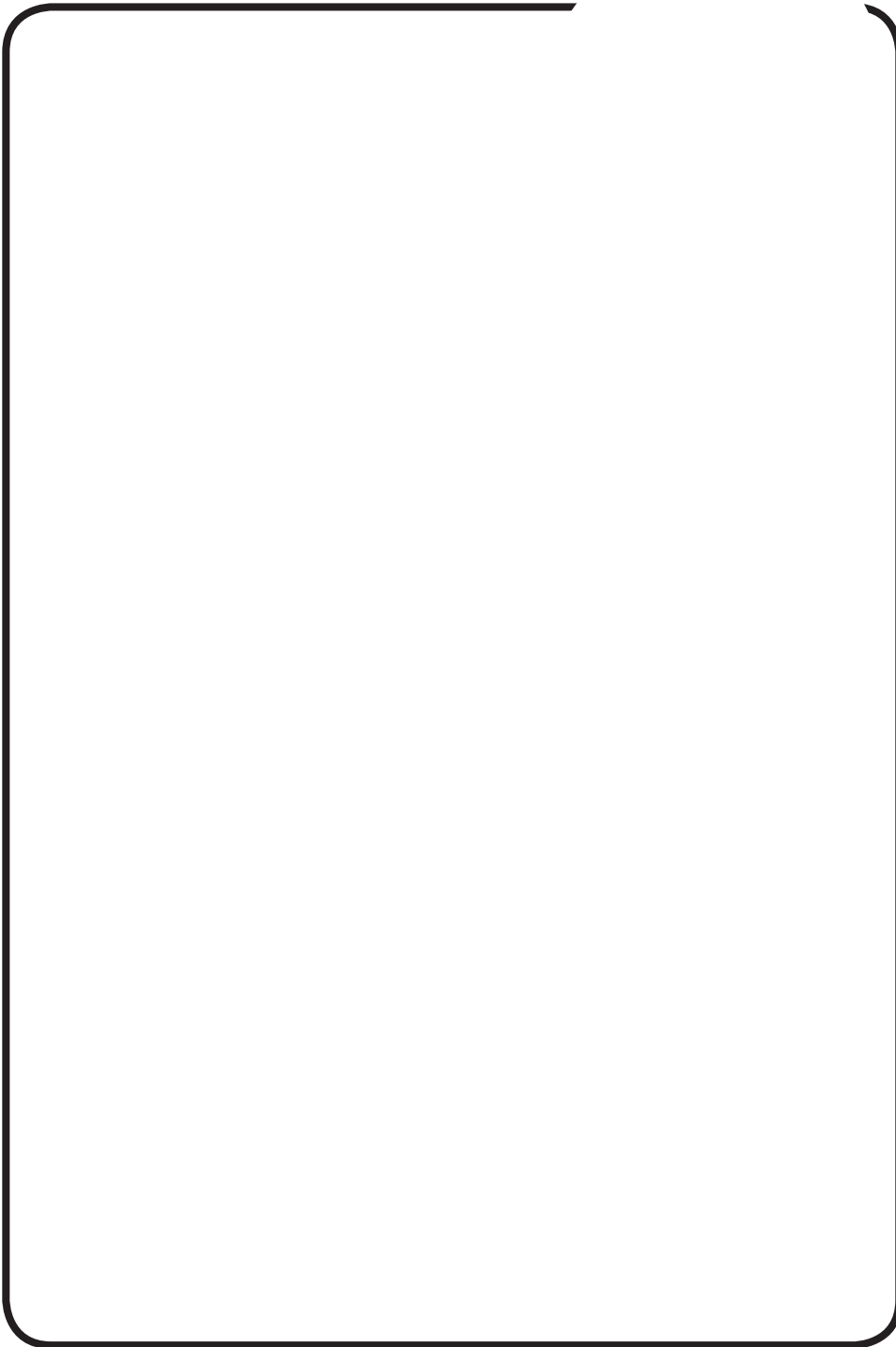

Real World Examples

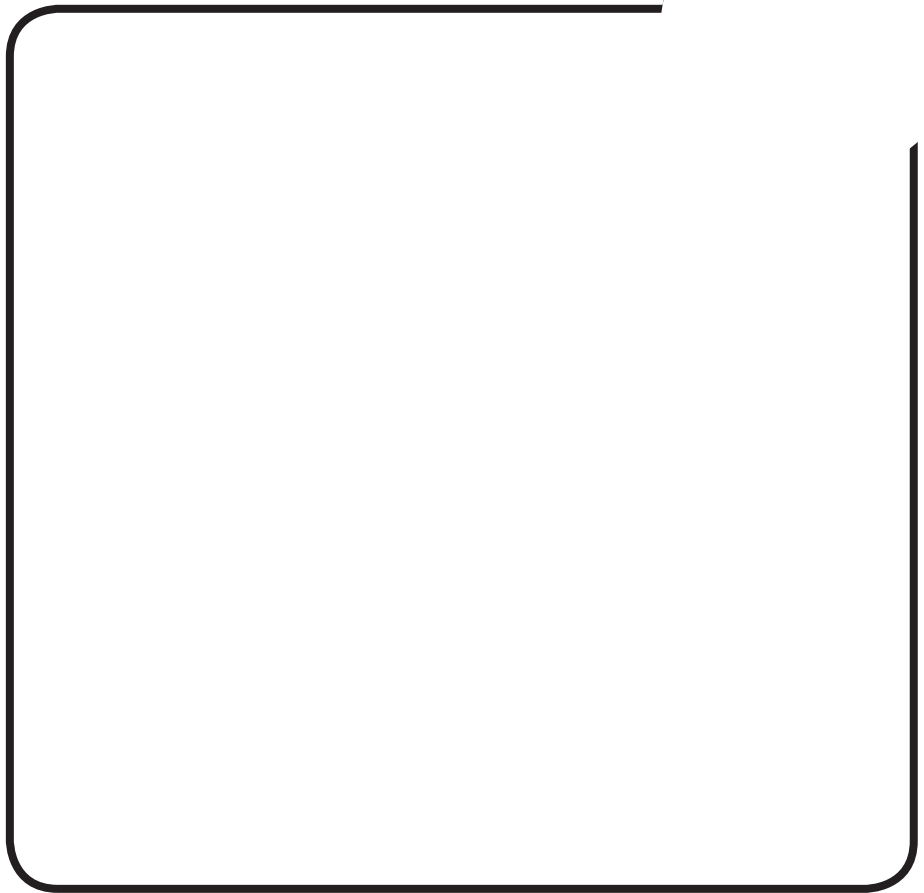

Key Rules in Conducting Surveys

1. When conducting surveys before and after a program, select your sample and solicit answers in the same way.
2. Try to ensure that the sample of women to be surveyed is representative of the group of women you want to reach in your prevention efforts.
3. Survey enough women in order to produce reliable results. A statistician at a local college, an epidemiologist, or a survey expert can help with the “power calculations” to determine the number of women you need to survey.
4. Depending upon your survey and your agency, your survey may require approval by a *human subjects review committee* or *institutional review board (IRB)*, a mechanism used to protect the rights and welfare of humans involved in research.
5. Try to eliminate any potential biases and threats to your survey’s validity. References for this subject can be found in Appendix B.
6. Train the people conducting your survey to ask questions and record answers in a standardized and consistent manner. Look to your local university research departments for help.
7. Consider asking your survey questions in the same way as other published surveys, such as the BRFSS which can be found in Appendix G. This allows for the comparison of your results with results from other populations.

4. 3-2-c Measure blood folate

Surveys of blood folate levels in reproductive-age women can be used to evaluate the effectiveness of a folic acid promotion program by measuring folate levels in a target population before and after the program. Projects such as these generally require *institutional review board (IRB)* approval and a special consideration of the *informed consent* process and procedures for handling and storing private information.

On a national level, the Third and Fourth National Health and Nutrition Examination Surveys (NHANES III and IV) will be used to evaluate changes in folic acid consumption. In addition, blood folate surveys of specific populations in other settings are being planned. For example, one state's family planning clinics will measure folate levels in blood obtained during routine client visits in order to assess the effectiveness of distributing free folic acid supplements. In another example from a managed care setting, blood folate levels will be measured in samples routinely drawn from women during their first prenatal visit to evaluate interventions to increase folic acid use. When more is learned about blood folate values, CDC will share information about this evaluation measurement.

4.3-2-d The pros and cons of counting NTDs for an outcome evaluation

One way to evaluate any NTD prevention program is to count the number of neural tube defects before and after the program's intervention. However, there are several reasons why counting NTDs is not a practical evaluation method for many community programs.

- In states or communities that do not have large numbers of births, the relatively small number of NTDs makes it difficult to see the impact of interventions on NTD rates.
- The increasing use of prenatal diagnosis of birth defects and subsequent selective terminations of pregnancies has caused the number of babies born with NTDs to decrease. To estimate accurately the number of pregnancies affected by an NTD, one must include prenatally diagnosed cases. However, identifying prenatally diagnosed cases is often difficult and resource-intensive.

Despite these drawbacks, changes in NTDs rates are being used to evaluate NTD prevention programs in several areas of the country. Birth defect surveillance programs or registries in your state can be a valuable resource or partner and should be made aware of your folic acid interventions and evaluations. You may be able to use data from these surveillance registries. See Appendix C for a list of state surveillance contacts.

4. 3-3 Analyze the Data

- **Reassess your program's goals and objectives.** How do changes in your community or agency relate to your original set of goals, objectives, or activities? Should you revise any of them now?
- **Identify activities where additional efforts are needed.** How do the resulting changes in your community or agency relate to a service or activity in the program? Were your objectives and activities completed? Were they successful? If not, why? (Lack of resources?)
- **Think about objectives met as a result of successful activities.** Should these activities be continued and strengthened because they appear to work well? Or should they be considered successful and completed? Do they need to be reassessed? Can they be expanded to apply to other audiences or situations?
- **Compare the costs and results of different activities.** How do the relative costs (including staff time) and results of different aspects of your program compare? Did some activities work well, but cost less than others?
- **Seek expert help to analyze data,** such as university statisticians or market researchers.

Additional information on analyzing data is provided in Appendix B.

Avoid These Common Errors

- *Concluding that a program works when it does not.* This error is usually a result of a poor evaluation design or data collection. Failure to account for the impact of other activities in the community that could have influenced the changes in knowledge about or use of folic acid is an example of a poor evaluation design. Choosing a sample of a population that does not represent the population your program tried to reach can also bias your results.
- *Concluding that the program did not produce any change because the results of your evaluation did not show any change.* This error can occur when the sample assessed in your evaluation is not large enough.
- *Concluding that a program was or was not effective, without information about the process.* This error commonly occurs when a program has not been monitored— **process evaluation** was not carried out (See section 4.2).
- *Concluding that a program has made an important impact when it has not.* Specify the amount of change that would have meaningful implications for your program. A statistical difference may not represent a meaningful difference.

4. 3-4 Garner Support for the Program

Letting others know about your program and its activities is a great way to make new contacts and learn about similar experiences, lessons learned, new ideas, or other potential resources in your community. It can also:

- Exhibit your program's effectiveness and demonstrate a need to continue your program in your county, community, or elsewhere.
- Interest other organizations in continuing or helping with some activities.

4. 3-5 Communicate Your Findings

- **Write an evaluation report.** An evaluation report is a formal record of your success. Written evidence can serve as a foundation for future NTD prevention efforts and help others to design their own programs. Some items to include in an evaluation report are:
 - A statement of the goal of the evaluation.
 - A discussion of the evaluation method and design.
 - A copy or explanation of your evaluation activity and/or questionnaire.
 - A summary of changes made in the program during and after your evaluation.
 - An estimate of the program's overall effectiveness. Share the results of your activity with the leadership of your agency or community.

- **Write a letter** about your findings to medical, public health, or health educational journals or to local professional newsletters.
- **Make a poster presentation** for a relevant professional or community meeting.
- **Send letters or brief reports to, telephone, or plan meetings** with peers in similar organizations.
- **Use the press** (print, television, and radio).
- **Write up a program description and gather sample materials to send to the CDC Folic Acid Promotion/NTD Prevention Clearinghouse.**

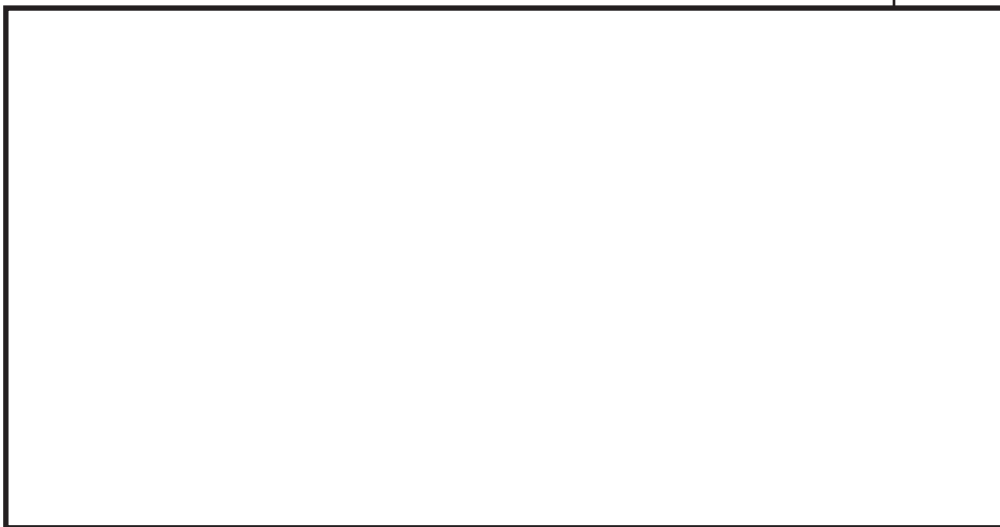
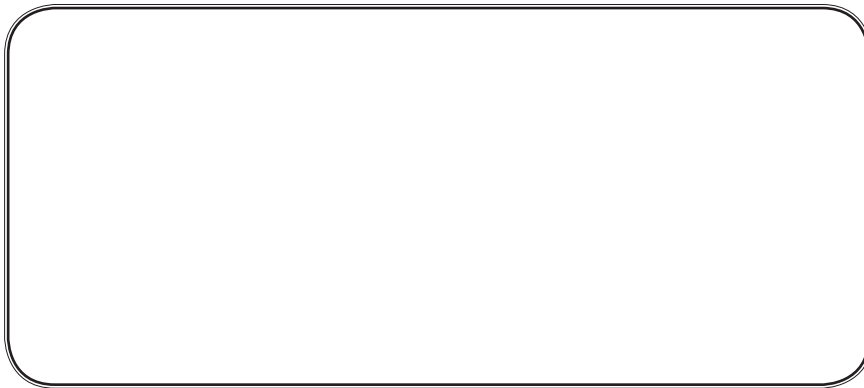

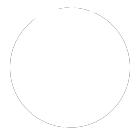

One Message Sent Out Many Different Ways

**Onondaga County Health Department
Syracuse, New York
Lloyd Novick, MD, MPH
Commissioner of Health
Amanda Nestor, MSW, CSW, Program Coordinator
Phone: 315-435-3252**

You can develop a far-reaching, innovative folic acid education program with the aid of numerous community partners. Dr. Novick's team enlisted the local chapter of the March of Dimes, many community organizations, hospitals, pharmacies, schools, grocery stores, retail stores, medical societies, and managed care organizations. These organizations provided channels to deliver the folic acid message. Women in the community had multiple opportunities to hear the message.

Such repetition of a message is an effective way to reach a target audience. The following is a brief summary of ways in which the various partners in this program delivered their message:

Media Activities

- Press conferences, news releases, articles
- Public service announcements
- Program representatives appearing as guests on radio call-in shows
- Program representatives appearing as featured guests on TV shows

Involvement of Medical/Managed Care Providers

- Meetings with folic acid as the subject
- Newsletters, articles, letters
- Posters, flyers, pamphlets, buttons, videos
- Prescription pads with folic acid prescriptions already printed
- Folic acid education requirements as a part of HMO/PPO contract negotiations

Activities in Pharmacies

- Folic acid brochure with each prescription dispensed
- Discount coupons for store-brand multivitamins
- Folic acid message incorporated in advertisements
- Distribution of promotional/educational materials

Projects in Grocery Stores

- Folic acid highlighted in articles in weekly circulars
- Folic acid message incorporated in TV, radio, and newspaper ads
- Folic acid message printed on grocery bags
- Audio messages on in-store PA/radio systems
- Folic acid ads on shopping carts
- Discount coupons on in-store products containing folic acid
- Seasonal produce display highlighting folate-rich fresh fruits and vegetables

Ventures with Women, Infants, and Children (WIC)

- Posters, buttons, brochures, video, newsletter messages on folic acid
- Message on WIC check holders
- Farmer's market coupons for foods rich in folate
- Screening for intake of foods rich in folate
- Displays of folic acid sources

Endeavors in Schools

- Educational training for teachers
- Message included in lesson plans in health and other classes
- Orange juice served in classes along with a lesson on folic acid
- Poster contests and displays
- Articles in staff and parent newsletters
- Instructional videos
- Information distributed to student health clinics in schools and colleges

Projects at Other Sites

- Paycheck inserts at work sites
- Posters/brochures at
 - Health clubs
 - Weight loss centers
 - Laundromats
 - Beauty salons
 - Churches
 - Restaurants
 - Bookstores
 - Food banks
 - Buses and taxi cabs
- Billboards

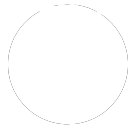

Focus Your Campaign Around a Celebrated Event

Oklahoma State Department of Health
Maternal and Child Health Service
Oklahoma City, Oklahoma
Kay Pearson, MS, RD, LD, Coordinator
Birth Defects Registry
Phone: 405-271-4480

Focusing your folic acid prevention campaign around a well-received, celebrated event such as Mother’s Day, Valentine’s Day, or Grandparents’ Day brings positive attention to folic acid in your community. The Oklahoma State Department of Health (OSDH), in collaboration with the Oklahoma Pharmacists Association and the March of Dimes Birth Defects Foundation, kicked off its campaign around Valentine’s Day. On February 10, the OSDH issued a news release stressing the importance of women taking folic acid before they become pregnant. The message ended with, “This is a gift we can give ourselves and future generations of Oklahomans. Happy Valentine’s Day! Folic Acid—Take it to Heart!”

In March for St. Patrick’s Day, a news release from the Commissioner of Health, J. R. Nida, MD, reminded all women between their teens and their forties to take at least 0.4 milligram of folic acid each day. This message ended with, “This St. Patrick’s Day wear a green ribbon. You can celebrate St. Patrick’s Day and help the March of Dimes and the Oklahoma State Department of Health spread the word about folic acid.” The March of Dimes green ribbon campaign was developed to raise awareness and support for

the prevention of NTDs and treatment of children with spina bifida. Green ribbons were made available, and people were encouraged to wear them.

Dr. Nida then proclaimed May, the month in which Mother's Day occurs, as Neural Tube Defect Prevention Month in Oklahoma. Colorful posters, buttons, and pamphlets were mailed to county health departments in April for use in May. Every pharmacy and many grocery stores, self-service laundries, physician offices, and other public locations throughout the state were mailed a poster and educational Mother's Day cards. Announcements on grocery bags and billboards were also prepared. The news release from Dr. Nida in May suggested that "(t)he ideal gift for women between their teens and forties is a bottle of multivitamins containing at least 0.4 milligram of folic acid." He also encouraged women to take this vitamin daily, even if they were not planning to become pregnant, since half of all pregnancies are not planned.

Other suggested promotional ideas included:

- Holding a "Happy Mother's Day! Folic Acid—Make It A Habit" raffle drawing, and giving away a one-year supply of multivitamins containing 400 micrograms of folic acid to women in the community.
- Giving a one-year supply of multivitamins with folic acid to all women getting married.

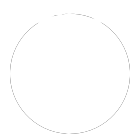

A Low-Budget Campaign Well-Planned From Beginning To End

Region 1 Perinatal Coordinating Council

Abingdon, Virginia

Buckey Boone, BA

Kristin Broome, MPH

Phone: 276-676-4501

Southwest Virginia's Folic Acid campaign was initiated by the Region 1 Perinatal Coordinating Council (RPCC) and funded by the March of Dimes, Virginia Chapter. Public education activities were designed to increase awareness and promote behavior changes concerning folic acid intake. Educational materials were tested for readability and pretested for an effective and appropriate message. The main message stated, "Spread the Word: Folic Acid Prevents Birth Defects." Consumption of a daily multivitamin was emphasized in the campaign, and a diet high in folic acid was discussed often. Following is a list of campaign activities:

- A banner designed for local health departments.
- Training for health departments and rural health clinic staff.
- A "Health Tip" focus on folic acid in hospital and pharmacy newspaper ads.
- A conference focused on folic acid and perinatal nutrition with guest speaker, Dr. Godfrey Oakley, from CDC.
- Initiation of the March of Dimes Green Ribbon Campaign.

- A news conference for all media.
- Public service announcements produced by local theater students.
- Posters and brochures produced and distributed by local nursing students and volunteer organizations.
- Radio and TV interviews introducing the folic acid message.
- A TV community calendar displaying folic acid activities.
- A one-day campaign in nine grocery stores to distribute information cards, green ribbons, and flyers and to display banners and labels for food high in folic acid.
- Presentations and folic acid information packets were provided to teachers in all schools from the fifth grade through the college level, including vocational schools. Packets contained folic acid and neural tube defect information, pre- and post-tests, lesson plans, enrichment activities, the campaign's video PSA, and a display board.
- A display board designed for use at health and county fairs, schools, and conferences.
- Local pharmacies and pharmaceutical companies provided samples of multivitamins.

This campaign ended in January 1998. A random telephone sample pre- and post-test survey of the target population was conducted to show the campaign's effectiveness. The evaluation results showed a 23% increase in folic acid awareness, a 20.1% increase in knowledge about folic acid and its benefits, and an 11% increase in folic acid use among the target population over a one-year period.

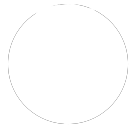

See Results From a Long-Term Commitment to NTD Prevention

Utah Department of Health

Disabilities Prevention Program

Salt Lake City, Utah

Marcia Feldkamp, PA, MSPH, Epidemiologist

Frederick I. White, Ed.D, Program Manager

Phone: 801-257-0566

In January 1995, Utah's Folic Acid Educational Campaign held planning sessions on how to increase awareness among women in their childbearing years. Statewide education was initiated in January 1996 in conjunction with the Mothers' March of the Utah Chapter of the March of Dimes. Volunteers went house to house throughout the state to request donations, discuss folic acid, and leave brochures on folic acid. Public service announcements were broadcast statewide on TV and radio. A fact sheet, poster, and newsletter articles were created, along with a bookmark targeting women who were not contemplating pregnancy but who were capable of becoming pregnant.

The second year of the campaign (1997) focused on educating health care providers (in addition to women of childbearing age) about the use of folic acid and the importance of consuming this vitamin prior to conception. Brochures were sent to health care providers and health care clinics in Utah. Folic acid fact sheets and bookmarks were provided to marriage license bureaus, and articles were provided to employers for inclusion with employee

paychecks. Bookmarks and posters continued to be distributed statewide to bookstores, libraries, family planning clinics, community clinics, and local health clinics as well as to speakers and organizers of community events, such as health fairs.

In addition to the various state health department agencies involved, several community and state partners participated in getting the message out. The Spina Bifida Association, the March of Dimes, the University of Utah Health Sciences Center, the Utah Broadcasting Association, Kinkos Copying Center, bookstores, Planned Parenthood clinics, and marriage license bureaus, as well as private businesses contributed to the effort.

In the first year and a half that Utah's Folic Acid Educational Campaign existed, the percentage of women aware of the benefits of folic acid increased from 38.5% to 47.1%.

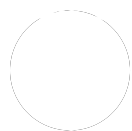

Collaborate in New Ways

Georgia Folic Acid Task Force

Atlanta, Georgia

Shira Ledman, MSW, Chair

Executive Director, Spina Bifida Association of Georgia

Phone: 770-939-1044

In 1998, the Georgia Folic Acid Task Force conducted a two-week educational campaign that began with the March of Dimes Walk America Day and concluded with Mother's Day. The Task Force planned and implemented several activities to promote the consumption of folic acid by all women of childbearing age:

- Georgia Governor Zell Miller proclaimed May as "Folic Acid Month."
- Task Force members hand-delivered press kits to radio and television stations throughout the state.
- At many of the 25 March of Dimes Walk America sites, volunteers wore shirts bearing the campaign message, "Folic Acid: A Vitamin for Life," and staffed display tables with folic acid brochures and posters. Some walk-site tables had special events. One site distributed orange juice samples provided by the Florida Department of Citrus; another site held cooking demonstrations with folate rich foods.
- Additional volunteers set up 112 community display tables throughout Georgia. WIC Clinic and Women's Health employees, FHA (Future Homemakers of America) groups, and high school students in family and consumer science classes staffed these tables and helped publicize the campaign message.

- Task Force members displayed folic acid information and gave speeches at professional conferences.
- The Georgia Unit of Teleflora (a floral delivery wire service) encouraged member florists to enclose a folic acid message with each Secretary's Day and Mother's Day arrangement. The Task Force designed and supplied the business-size cards with the folic acid message. Florists also received a folic acid fact sheet, a Task Force fact sheet, a campaign press release, a stamped evaluation post card, and a campaign endorsement memo from the Georgia Teleflora leadership.

As plans for the campaign progressed, some family and consumer science teachers decided to include messages and projects related to folic acid in their curricula. When the Task Force requested volunteers to staff community display tables during the two-week campaign, the family and consumer science teachers encouraged students to participate. Students at one high school staffed folic acid tables at their local grocery store and plan to enter their display in the regional FHA competition. The students will participate in the "Illustrated Talk" area of the competition. They will give a speech about folic acid and demonstrate how they shared this information with their classmates and community. By taking part in the campaign and the competition, students learned about and spread the word regarding the importance of folic acid. High school-age women are a very important target for the folic acid message.

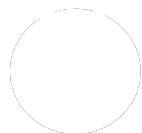

Start Young: A School Intervention

Puerto Rico Department of Health

San Juan, Puerto Rico

Idalina Montes-De Longo, MD

PRDH, Folic Acid Campaign Coordinator

Phone: 787-765-2929

Puerto Rico has a higher incidence of NTDs than most areas of the United States. In 1994, the Puerto Rico Department of Health (PRDH) began planning an island wide campaign for the prevention of NTDs. A public policy statement was issued encouraging the use of folic acid in all women of childbearing age from 10 years to 50 years. The PRDH developed a network of partners to support the campaign. Beginning in 1995, the following activities were initiated:

- A data collection system was established to track the occurrence of NTDs.
- Audience-appropriate educational materials (brochures, a video, slide show presentations, folders of information, buttons, and a poster) were designed and distributed. Health professionals received their supplies through training sessions and seminars. Women of childbearing age acquired the educational materials at training sessions, health fairs, and places women on the island frequent, such as grocery stores and pharmacies.

- Partnerships were developed with:
 - The Department of Education
 - Interagency groups
 - Private corporations
 - CDC
- 2000 health and education professionals were trained to educate women about folic acid.
- Miss Puerto Rico 1996 became a spokesperson for the folic acid campaign and participated in a public service announcement that has been shown in theaters island wide. Also, young adults with spina bifida have been actively involved with spreading the prevention message.
- A self-administered questionnaire, including questions from the BRFSS in Appendix G, was created to evaluate the effectiveness of the campaign.
- Folic acid tablets were distributed to medically indigent, reproductive-age women.

More than 63,000 babies are born annually in Puerto Rico. Seventy percent of pregnancies are unplanned, and approximately 20% of the live births occur in women 19 years or younger. Aware of a higher incidence of NTD affected pregnancies in younger women, the campaign committee collaborated in a special partnership with the Department of Education. Together, the partners planned three strategies to deliver the folic acid message to girls and young women. The first strategy was to include the folic acid message in the school health curricula at the elementary, intermediate, and high school levels. Now all female students in the public school system are educated about the need for daily folic acid supplements. The second strategy was to involve the school nutritionists to increase the amount

of food folate in school lunches. As a result, folate-rich menus are offered at all school lunch programs in the island's public schools. The third strategy was to train adolescent peer leaders to spread the word. These peer leaders have interacted not only with members of their own grade levels, but those of other grade levels in their schools, too. They have also visited other schools in their districts to share information about the importance of folic acid.

Evaluation of this campaign demonstrated that the percentage of women who knew about the importance of taking folic acid increased from 49% in 1996 to 62% in 1997. Further program evaluation is being done as the campaign continues.

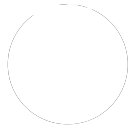

Possibilities for Direct Folic Acid Supplementation and Evaluation in Family Planning Clinics

**Georgia Department of Human Resources
Division of Public Health
Women's Health Section
Family Planning Program
Atlanta, Georgia
Arminda Hicks, RN-C, NP, Director
Phone: 404-657-2884**

The Family Planning Program of the Georgia Department of Human Resources along with the Spina Bifida Association of Georgia, the Georgia Chapter of the March of Dimes, and the Centers for Disease Control and Prevention developed and organized an NTD prevention campaign for public health departments in Georgia. Components of the campaign include:

- A survey of women's knowledge, attitudes, and behaviors about the prevention of NTDs with folic acid before they received education in the health departments.
- Educational brochures, posters, videos, and refrigerator magnets.
- Distribution of three-month supply of folic acid supplements and scheduled follow-up visits.

-
- A reassessment survey of women's knowledge, attitudes, and behaviors about the prevention of NTDs with folic acid and an offer of an additional three months supply of folic acid supplements at each follow-up visit.

The measurable outcomes of this folic acid supplementation project are:

- The number of clients consuming an adequate amount of folic acid daily.
- The number of clients given folic acid.
- The number of clients continuing to take folic acid for a 12-month period.
- Changes in clients' knowledge about the benefits of folic acid.

Program personnel also gathered information about the reasons women do not consume adequate amounts of folic acid and about barriers to changing behavior. In addition, there are plans to obtain blood folate measurements from a sample of these women. These measurements could assess changes in women's use of folic acid supplements.

Selected Ideas for a Community-Based Folic Acid Promotion Program

1. Ask your county executive, legislative leader, mayor, or town supervisor to proclaim a Folic Acid Awareness Week in your community. Use the sample proclamation provided in Appendix I. Then, plan a signing party, where people sign their names in support of the campaign, and invite interested organizations and possible partners.
2. Assemble representatives of interested organizations to discuss ways to promote the folic acid message. Consider working together on community outreach and education projects.
3. Provide local newspapers, television, and radio stations with information so they can create related stories. Help educate editors and reporters about how folic acid can help to reduce birth defects. Include the names and contact numbers of local parents who have had a child with an NTD and who have agreed to provide interviews.
4. Ask your county health officer or another recognized health care provider to talk with the media about the benefits of folic acid. Make all the necessary arrangements for the interview.
5. Complete the fill-in-the-blank news release provided in Appendix I. Hand deliver it to community page newspaper editors, local grocery chains, and local health organizations that provide information to patients.

6. Give copies of the public service announcements to radio and television public service program directors and ask that they air the spots during Folic Acid Awareness Week and throughout the year. Samples of PSAs are provided in Appendix I.
7. Conduct a letterwriting campaign on the benefits of folic acid. For example, write letters to the editor and opinion pieces for local newspapers, school boards, women's circulars, church bulletins, and medical association and girl scout newsletters. Sample letters are provided in Appendix I.
8. Design and send inserts in direct mailings, such as utility bills. A sample insert is provided in Appendix I.
9. Join with local physicians, allied health organizations, or health care facilities to develop a community speaker's bureau on folic acid.
10. Provide exhibits for health fairs in public places, such as shopping malls and schools.
11. Offer to provide guest speakers for meetings, classes, conferences, and other gatherings of groups in your community who reach any population of childbearing-age women during Folic Acid Awareness Week or throughout the year. A presentation guide is provided in Appendix I.

12. Meet with school cafeteria supervisors to talk about the benefits of foods with folic acid and encourage the inclusion of folic acid-rich foods in school menus. Meet with school nurses or health teachers to discuss ways to talk about folic acid to students. Guides to school presentations are provided in Appendix I.

13. Create for volunteers a pamphlet providing information about your birth defect prevention project, what neural tube defects are, how they can be prevented, and what volunteers can do to help your program. Hand out the pamphlets at health fairs, health care organizations that serve mothers and girls, hair and full service salons, workout facilities, and day care centers. A sample fact sheet for volunteers can be found in Appendix I.

Ideas for Health Care Providers

1. Ask editors of medical newsletters, journals, or bulletins to print articles.
2. Gather a group of health care professionals in the community to be featured on local television and radio shows.
3. Convince medical providers to present the folic acid message to medical staff while on grand rounds, and create educational “prescription pads” as a reminder note to practitioners.
4. Provide packets of flyers, posters, articles, and buttons that health care providers can distribute.
5. Start a folic acid voice mail phone line at your clinic or local health department.

For Family Planning Clinics/Teen Health Clinics/ Prenatal Clinics/Maternal Support Services/WIC Clinics/Managed Care Providers: Develop a comprehensive package for health care workers to teach women about the need for folic acid. Have each health care professional wear a folic acid button while at work. Encourage workers to screen women for risk factors and folic acid intakes. Include information to support supplement use and dietary intakes of folic acid by identifying where to buy supplements in your community and which foods are high in folic acid.

For Children’s Special Health Care Services: Encourage local services to find out every woman’s history of NTD-related pregnancies and to provide each woman with information about folic acid.

For Early Periodic Screening Diagnosis and Treatment Programs (EPSDT): Provide information on folic acid to parents of children participating in screening program.

For First Post-Partum Visit: Provide information to midwives or medical OB/gyn office staff to pass on to new mothers as they resume sexual activity.

Keep Up With New Campaign Ideas

- Inform **CDC** of your own efforts so that we can share your ideas with others.

Call: 1-800-232-4636 (CDC-INFO)

Fax: 404-498-3550

E-mail: Flo@cdc.gov

Write to: CDC Folic Acid Promotion/NTD Prevention Clearinghouse

1600 Clifton Road, N.E.

Mailstop E-86

Atlanta, GA 30333

- Watch for updates on the CDC Birth Defects Web Page:
<http://www.cdc.gov/ncbddd/bd>

Glossary of Terms

Approach A means by which to move toward meeting an objective or goal.

Central Location Intercept Interviews Interviews conducted with respondents stopped at a highly trafficked location frequented by individuals typical of the desired target audience.

Community An interacting population of various kinds of individuals sharing some commonality together within a larger society.

Epidemiologist A scientist who deals with the incidence, distribution, and control of disease in a population.

Focus Group Interviews A type of qualitative research in which an experienced moderator leads about 8 to 10 respondents through a discussion of a selected topic, allowing them to talk freely and spontaneously.

Gatekeeper Someone you must work with before you can reach a target audience (e.g., a schoolteacher) or accomplish a task (e.g., a television public service director).

Goal The overall improvement the program will strive to create.

Human Subjects Review Board A specially constituted review body established or designated by your agency for the purpose of protecting the rights and welfare of human subjects involved in research projects.

In-Depth Interviews A form of qualitative research used to find out what people think and feel about a given topic.

Informed Consent Persons who participate in research should have the opportunity to choose what will or will not happen to them. Three necessary elements of informed consent are full disclosure, adequate comprehension, and voluntary choice.

Institutional Review Board (IRB) A specially constituted review body established or designated by your agency for the purpose of protecting the rights and welfare of human subjects involved in research projects.

Objective A quantifiable statement of a desired program achievement necessary to reach a program goal.

Outcome Evaluation Evaluation conducted to identify a program's accomplishments and effectiveness; also called end-stage or impact evaluation.

Pretest A type of formative research that involves systematically gathering the reaction of target audiences to messages and materials before they are produced in final form.

Process Evaluation Evaluation to study the functioning of program implementation steps. Includes assessments of quantities and distribution of materials, of occurrence and depth of program activities, and other measures of how the program process is working.

PSA (Public Service Announcement) A message for the public's good for which distributors do not charge.

Qualitative Research Research that is subjective in that it involves obtaining information about feelings and impressions from small numbers of respondents. The information gathered usually should not be described in numerical terms, and generalizations about the target populations should not be made.

Quantitative Research Research designed to gather objective information from representative, random samples of respondents; results are expressed in numerical terms (e.g., 35% are aware of X and 65% are not). Quantitative data are used to draw conclusions about the target audience.

Reach Term refers to the number of different people or households exposed to a specific media message during a specific period of time.

Self-Administered Questionnaires Questionnaires that are mailed directly to and filled out by respondents themselves or filled out by respondents gathered at a central location.

Target Audience The desired or intended audience for program messages and materials. The primary target audience consists of those individuals the program is designed to affect. The secondary target audience is that group (or groups) that can help reach or influence the primary target audience. The target audience can also be *segmented* or broken down into smaller subgroups.

Theater Tests A large group of audience members reviews draft materials, which are embedded into other materials, and are asked to respond to brief written surveys.

Contents of the Appendices

Appendices are located on the diskette in the back of this manual. Files are saved in WordPerfect 6.0. They can be retrieved in WordPerfect and Word, but they should not be saved in Word. Tables are subject to change when converting to Word or any other program. Contact CDC if you need hard copies.

Appendix A

Glossary of Terms (also on diskette)

Appendix B

Useful Literature and Information

Frequently Asked Questions and Answers

Sources of Folic Acid and Folate

 Products with 400 micrograms per serving, 100% of the daily value

 List of sources of folate from foods

Sample Nutrition Label Highlighting Folic Acid

References on Living With Spina Bifida

Spina Bifida Internet Mailing Lists and News Groups

References on Folic Acid and NTDs

Articles on Folic Acid and NTDs

Folic Acid Information for Health Care Professionals and Childbearing-Age Women

References on Making Health Campaigns Effective

More Information on...

 “Step 1: Mobilizing Your Community”

 Getting Information About Your Audience

 Selecting Your Audience

 Learning About Women’s Health Beliefs and Practices

Determining Women’s Consumer and Media Habits
Addressing Special Populations of Women
Creating Messages and Materials
Writing Easy-To-Read Materials
Testing Messages and Materials/Focus Group Cost Breakdown
Testing for Readability—SMOG Readability Test
Delivering Your Program
Tracking and Evaluating Your Program

Appendix C

Contacts

Professionals Who Serve Families Affected by NTDs
Organizations That Serve Families Affected by NTDs
State Birth Defects Surveillance Systems
Potential Prevention Campaign Partners in Your Community

Appendix D

Involving Others

Sample Cover Letters
Community Partnership Activity Lists

Appendix E

Planning for Action

Program Planning Worksheet
Blank Charts to Outline Activity/Tasks
Sample of a Timetable Format
Camera-Ready Materials
Appropriate Methods for Your Budget
Foundations for Grant Seekers

Appendix F

Delivering Your Program

Activity Packets

Sample Checklist

Appendix G

Sample Survey Questions

Before and After Survey Questions

Demographic Questions

Use and Knowledge of Folic Acid

Attitudes Toward Vitamins and Pregnancy

Appendix H

More About the Media

Characteristics of Mass Media Channels

Media Costs

Tips to Work with the Media

Creating Your Own Media Materials

Appendix I

Materials to Use and Adapt

Sample Proclamation

News Releases

Media Advisory

Broadcast Public Service Announcements

Newspaper Article

Press Conference Announcements

Newsletter Inserts

Folic Acid Curricula

- Letter for educators
- Outline for folic acid education speech
- Delivering a speech/speaking tips
- NTD quiz for audience
- Fact sheet

Training Kit

- Letter for health care provider receiving a training kit
- Slide show format for health care providers
- Instructions for administration of pre- and posttests
- Neural tube defects pretest
- Neural tube defects posttest
- Answer sheet
- Answer key to pretest
- Answer key to posttest
- Answer sheet to pretest and posttest
- Contact information for other training kits

Preventing Neural Tube Birth Defects—A Prevention Model and Resource Guide

Evaluation Form

Please answer the following questions and mail this form to the Centers for Disease Control and Prevention, 1600 Clifton Road, N. E., Mailstop E-86, Atlanta, GA 30333. You will then be placed on our mailing list to receive information about folic acid prevention programs and activities. Thank you for all your effort to get the word out about folic acid.

Name: _____ Title: _____

Organization: _____

Address: _____

City: _____ State: _____ Zip Code: _____

Business Phone: _____ Fax: _____ E-Mail: _____

1. Will your organization use the materials provided in the Resource Guide to help promote the consumption of folic acid among women of childbearing age?

Yes

No (Please do not answer any more questions, but please mail the form back to us.)

2. How do you plan on using them?

3. Who else do you plan to involve in your efforts? (Partners or potential partners)

4. When do you think you will be using these materials?

Within the next 3 months

4-6 months

7-9 months

10-12 months

13-15 months

16 or more months

5. Where are you most likely to use these materials to promote folic acid? Check as many as apply.

Work sites

Schools

Hospitals/Clinics

Community-wide

Churches/Temples

Statewide

Businesses

Other (Please indicate)

6. Whom do you intend to reach with these materials? Please be as specific as possible and write down other defining characteristics about your target audience (e.g., vitamin usage, pregnancy intention, socio-economic status, or religious beliefs). If you are reaching more than one group, please specify groups in priority order.

Group	Race	Age
<input type="checkbox"/> Women	<input type="checkbox"/> Black	<input type="checkbox"/> 18-24 years old
<input type="checkbox"/> Health Care Providers	<input type="checkbox"/> Aleutian/Eskimo	<input type="checkbox"/> 25-34 years old
<input type="checkbox"/> Policy makers	<input type="checkbox"/> Asian/Pacific Islander	<input type="checkbox"/> 35-44 years old
<input type="checkbox"/> Grandparents	<input type="checkbox"/> White	<input type="checkbox"/> 45-54 years old
<input type="checkbox"/> Parents	<input type="checkbox"/> Hispanic	<input type="checkbox"/> 55-64 years old
<input type="checkbox"/> Other (Please specify)	<input type="checkbox"/> American Indian	<input type="checkbox"/> 65 years or older
	<input type="checkbox"/> Other (Please specify)	

7. Will this be your organization’s first folic acid promotion effort?

- Yes
- No

8. On a scale of 1 to 5, please rate how confident you are in your ability to do the following:

Step 1: Mobilize Your Community

1	2	3	4	5
Not at all	Not much	Some	A lot	Completely

The amount of information in Step 1 was

1	2	3
Not enough	Just the right amount	Too much

The presentation and quality of the information in Step 1 was

1	2	3
Hard to understand (too technical)	Neither hard nor easy	Easy to understand

The examples in Step 1 were

1	2	3
Not helpful	Somewhat helpful	Very helpful

9. On a scale of 1 to 5, please rate how confident you are in your ability to do the following:

Step 2: Plan for Action

1	2	3	4	5
Not at all	Not much	Some	A lot	Completely

The amount of information in Step 2 was

1	2	3
Not enough	Just the right amount	Too much

The presentation and quality of the information in Step 2 was

1	2	3
Hard to understand (too technical)	Neither hard nor easy	Easy to understand

The examples in Step 2 were

1	2	3
Not helpful	Somewhat helpful	Very helpful

10. On a scale of 1 to 5, please rate how confident you are in your ability to do the following:

Step 3: Test Your Messages and Materials

1	2	3	4	5
Not at all	Not much	Some	A lot	Completely

The amount of information in Step 3 was

1	2	3
Not enough	Just the right amount	Too much

The presentation and quality of the information in Step 3 was

1	2	3
Hard to understand (too technical)	Neither hard nor easy	Easy to understand

The examples in Step 3 were

1	2	3
Not helpful	Somewhat helpful	Very helpful

10. On a scale of 1 to 5, please rate how confident you are in your ability to do the following:

Step 4: Deliver, Track and Evaluate Your Program

1	2	3	4	5
Not at all	Not much	Some	A lot	Completely

The amount of information in Step 4 was

1	2	3
Not enough	Just the right amount	Too much

The presentation and quality of the information in Step 4 was

1	2	3
Hard to understand (too technical)	Neither hard nor easy	Easy to understand

The examples in Step 4 were

1	2	3
Not helpful	Somewhat helpful	Very helpful

12. What suggestions do you have for improving this guide?

Thank you so much for your help! CDC will use your suggestions to revise future editions of the Resource Guide.